

Engineered Wood Handbook and Grade Glossary



APA

WOOD

The Natural Choice



Engineered wood products are a good choice for the environment.

They are manufactured for years of trouble-free, dependable use. They help reduce waste by decreasing disposal costs and product damage. Wood is a renewable resource that is easily manufactured into a variety of viable products.

A few facts about wood.

▪ **We're growing more wood every day.** Forests fully cover one-third of the United States' and one-half of Canada's land mass. American landowners plant more than two billion trees every year. In addition, millions of trees seed naturally. The forest products industry, which comprises about 15 percent of forestland ownership, is responsible for 41 percent of replanted forest acreage. That works out to more than one billion trees a year, or about three million trees planted every day. This high rate of replanting accounts for the fact that each year, 27 percent more timber is grown than is harvested. Canada's replanting record shows a fourfold increase in the number of trees planted between 1975 and 1990.

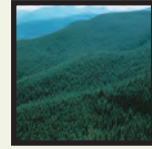

▪ **Life Cycle Assessment shows wood is the greenest building product.**

A 2004 Consortium for Research on Renewable Industrial Materials (CORRIM) study gave scientific validation to the strength of wood as a green building product. In examining building products' life cycles – from extraction of the raw material to demolition of the building at the end of its long lifespan – CORRIM found that wood was better for the environment than steel or concrete in terms of embodied energy, global warming potential, air emissions, water emissions and solid waste production. For the complete details of the report, visit www.CORRIM.org.

▪ **Manufacturing wood is energy efficient.**

Wood products made up 47 percent of all industrial raw materials manufactured in the United States, yet consumed only 4 percent of the energy needed to manufacture all industrial raw materials, according to a 1987 study.

Material	Percent of Production	Percent of Energy Use
Wood	47	4
Steel	23	48
Aluminum	2	8



▪ **Good news for a healthy planet.** For every ton of wood grown, a young forest produces 1.07 tons of oxygen and absorbs 1.47 tons of carbon dioxide.

Wood: It's the natural choice for the environment, for design and for strong, lasting construction.

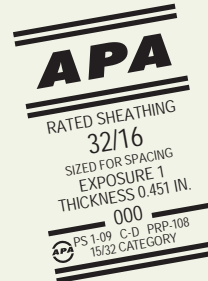

NOTICE: The recommendations in this guide apply only to products that bear the APA trademark. Only products bearing the APA trademark are subject to the Association's quality auditing program.

This glossary from *APA – The Engineered Wood Association* is designed as a handy reference guide to engineered wood products and common construction terminology. It contains up-to-date information about APA Performance Rated Panels, plywood siding, sanded grades, panel construction systems, engineered wood products, grading terminology, fasteners, finishing and much more.

For more detailed information about APA engineered wood products and construction systems, contact APA, 7011 So. 19th Street, Tacoma, Washington 98466, or call the APA Product Support Help Desk at (253) 620-7400.

The Association maintains a comprehensive inventory of publications for architects, builders, dealers, do-it-yourselfers and others who use and specify wood structural panel products. Visit the APA Publication Library at www.apawood.org to access more than 400 publications available for instant PDF download or hard-copy purchase.

A

A-A

A sanded plywood panel with A-grade face and back plies and D-grade inner plies. Bond classification is Exposure 1. Commonly used for cabinets, built-ins, furniture, partitions and other interior or protected applications where a smooth surface or appearance quality on both sides is important.

A-A • G-1 • EXP 1 • 0.734 IN. • APA • 000 • PS 1-09 • 3/4 CAT

A-A Exterior

A sanded plywood panel with A-grade face and back plies and C-grade inner plies. Bond classification is Exterior. Commonly used for fences, built-ins, signs, boats, cabinets, commercial refrigerators, shipping containers, tanks, tote boxes, ducts and other exterior or high moisture applications where a smooth surface or appearance quality on both sides is important.

A-A • G-1 • EXT • 0.734 IN. • APA • 000 • PS 1-09 • 3/4 CAT

A-B

A sanded plywood panel with A-grade face, B-grade back and D-grade inner plies. Bond classification is Exposure 1. Commonly used as a substitute for A-A where the appearance of one side is less important.

A-B • G-1 • EXP 1 • 0.234 IN. • APA • 000 • PS 1-09 • 1/4 CAT

A-B Exterior

A sanded plywood panel with A-grade face, B-grade back and C-grade inner plies. Bond classification is Exterior. Commonly used as a substitute for A-A Exterior where the appearance of one side is less important.

A-B • G-1 • EXT • 0.234 IN. • APA • 000 • PS 1-09 • 1/4 CAT

A-C Exterior

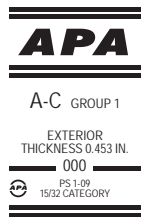

A sanded plywood panel with A-grade face, C-grade back and C-grade inner plies. Bond classification is Exterior. Commonly used for soffits, fences, boxcar and truck linings, farm buildings, tanks, commercial refrigerators and other high-moisture applications where the appearance or smoothness of only one side is important.

Acrylic Resin

An ingredient of water-base (latex) paints and stains. Synthetic resin with excellent weathering characteristics. Acrylics can be colorless and transparent or pigmented.

Adhesive

Adhesives are used in the manufacture of engineered wood products and in a variety of construction uses.

Used for manufacturing engineered wood products

APA trademarked plywood and LVL is manufactured using phenolic adhesive. APA trademarked OSB is manufactured using 1) phenolic adhesive, 2) isocyanate adhesive or 3) a combination with phenolic in the faces and isocyanate in the core.

APA trademarked I-joists use phenolic, melamine, and polyurethane adhesives in web to web and web to flange joints.

APA trademarked glulam beams use phenol-resorcinol and melamine adhesives in face and end joint bonds.

Used for building site or home projects

Urea or white glues are used in indoor, dry applications such as cabinets or furniture. Follow manufacturer's recommendations.

Resorcinol glue is used in high moisture applications such as farm buildings or boats. Follow manufacturer's recommendations.

Many adhesives, preferably in conjunction with nails or other fasteners, produce strong joints in wood structural panel construction. Type depends on purpose and exposure of finished product.

Other available adhesives include: **Hot melt glues** – for relatively small parts. Remember they cool and set quickly. **Epoxy glues** – limited use; most are not formulated for wood and are expensive. **Contact Cements** – useful for applying laminates and edge stripping to plywood. Not recommended for structural joints. **Wall panel nonstructural adhesives** – handy for applying decorative paneling or facing. May require a few nails per panel to position panels while glue sets. Structural adhesive is not recommended for applying wood structural panel wall sheathing. **Casein glues** – slow setting, permitting easier construction of difficult assemblies.

Construction adhesives are single-part elastomeric adhesives of various formulations, normally job site-applied with a caulking gun. They are designed for various applications such as nail-glued floors to improve floor performance and reduce squeaks.

A-D

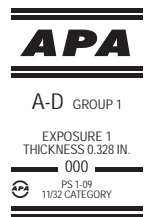

A sanded plywood panel with A-grade face, D-grade back and D-grade inner plies. Bond classification is Exposure 1. Commonly used for paneling, built-ins, shelving, partitions and other interior or protected applications where the appearance or smoothness of only one side is important.

AFG-01

A performance specification developed by APA for glues recommended for use in the APA Glued Floor System. AFG-01 requires that glues applied at the job site be sunlight resistant, strong under many moisture and temperature conditions, and able to fill gaps. Considered equivalent to ASTM D3498, Adhesive for Field-Gluing Plywood to Wood Framing.

Aggregate-Coated Panel

A panel coated with stone chips imbedded in a resin coating.

Air-Dried

See SEASONING.

Air Barrier

A solid material that blocks air flow, used to enclose structures to prevent the passage of moisture laden air into the interior of the wall where it could condense on cold surfaces. May be placed on inside or outside wall surfaces of structure. Most often placed on outside surface where it also fulfills the code requirement for a weather barrier.

Anchor Bolt

Bolts that tie the sill plate and thus the frame of a structure to its foundation.

APA – The Engineered Wood Association

The trade organization representing manufacturers of plywood, OSB, glued laminated timber, I-Joists, Rim Board[®] and structural composite lumber (SCL). The Association has three main functions: 1) research to improve wood structural panel (plywood and OSB) and other engineered wood products and systems, 2) quality inspection and testing to assure the manufacture of high quality wood structural panel and engineered wood products, and 3) promotion of engineered wood products and building systems. Commonly referred to as “APA,” and previously known as the American Plywood Association.

APA Glued Floor System

A floor system developed by APA in which a single layer of APA RATED STURD-I-FLOOR panels (or subflooring in the case of double-layer construction) is glue-nailed to wood joists. The bond is so strong that floor and joists behave like an integral unit, increasing floor stiffness and greatly reducing floor squeaks and nail pops. Only construction adhesives conforming to APA specification AFG-01 or ASTM D3498 are recommended for use with the system. See T-BEAM.

APA Performance Rated Panels[®]

Panel products developed by APA, such as APA RATED SHEATHING, APA RATED STURD-I-FLOOR and APA RATED SIDING, designed and manufactured to meet performance criteria for specific end-use applications. APA Performance Rated Panels can be manufactured as conventional veneered plywood, as composites (veneer faces bonded to reconstituted wood cores) or as mat-formed panels (oriented strand board). The trademarks on APA Performance Rated Panels include a Span Rating denoting the maximum recommended spacing of supports over which the panel should be placed for the designated end use and the bond classification of the panel.

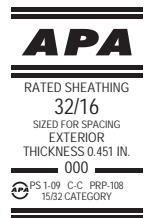
APA Rated[®] Sheathing

An APA Performance Rated Panel designed and manufactured specifically for residential and other light frame wall sheathing, roof sheathing and subflooring applications. APA RATED SHEATHING can be manufactured with Span Ratings of 12/0, 16/0, 20/0, 24/0, 24/16, 32/16, 40/20 and 48/24, in Performance Categories ranging from 5/16 to 3/4, and in two bond classifications – Exterior and Exposure 1.

APA Rated® Siding

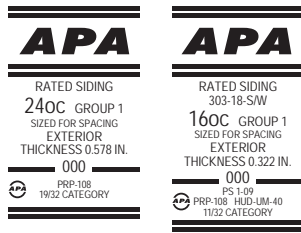

A grade designation covering APA proprietary siding products. Commonly used, in addition to siding, for fencing, soffits, wind screens and other exterior applications. Can be used for interior paneling. Can be manufactured as conventional veneered plywood, as a composite or as oriented strand board siding. Both panel and lap siding are available. Special surface treatment such as V-groove, channel groove, deep groove (such as APA Texture 1-11), brushed, rough sawn and texture-embossed (MDO). Span Rating (stud spacing for siding qualified for APA Sturd-I-Wall applications) and face grade classification (for veneer-faced siding) indicated in trademark.

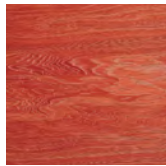

Brushed



Rough sawn

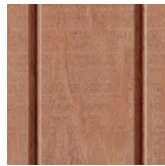

APA Texture One-Eleven®

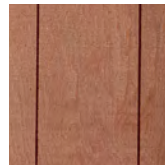

Kerfed

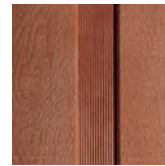

Reverse board & batten



Channel groove

APA Rated Sturd-I-Floor®

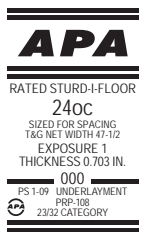

An APA Performance Rated Panel designed and manufactured specifically for residential and other light frame single-floor (combined subfloor-underlayment) applications for use under carpet. APA RATED STURD-I-FLOOR can be manufactured with Span Ratings of 16, 20, 24, 32 and 48 oc, in Performance Categories ranging from 19/32 to 1-1/8, and in two bond classifications – Exterior and Exposure 1. Panels are available with either square edges or tongue-and-groove edges as specified. APA RATED STURD-I-FLOOR 48 oc plywood, historically called 2-4-1, is also used in heavy timber roof construction.

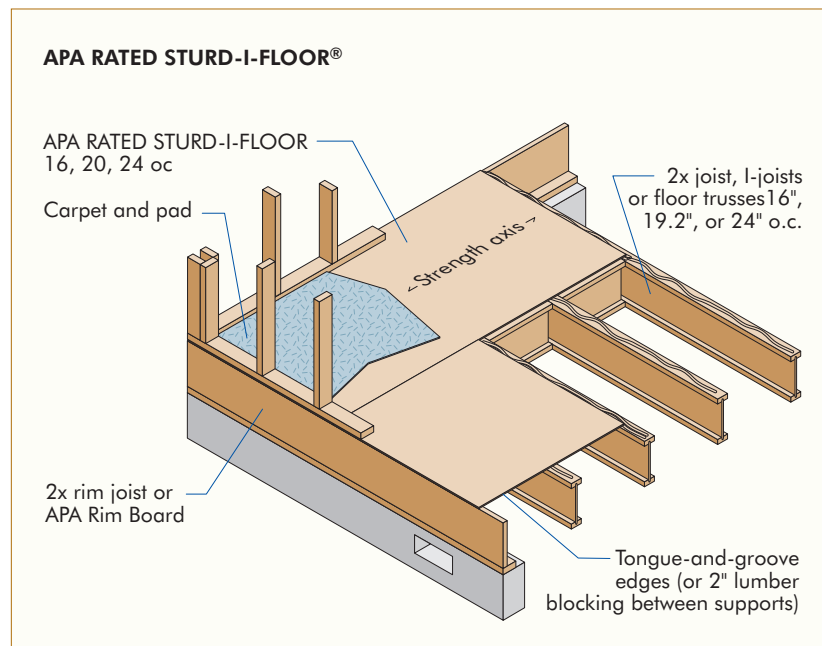

APA Sturd-I-Wall®

A construction system in which APA Rated Siding panels or lap are attached directly to studs (single wall) or over nonstructural wall sheathing, such as fiberboard, gypsumboard or rigid foam insulation. APA Siding bearing a Span Rating of 24 oc in the trademark can be applied vertically direct to studs spaced 24 inches on center. Siding with a Span Rating of 16 oc can be used vertically direct to studs 16 inches on center. Panels with either Span Rating can be applied direct to studs 24 inches on center with face grain horizontal provided horizontal joints are blocked.

APA Trademark

APA – The Engineered Wood Association is an approved quality supervision and testing agency for wood structural panels and other engineered wood products. Typical trademarks of APA member-manufactured products are shown throughout this brochure. See QUALITY INSPECTION AND TESTING.

APA STURD-I-WALL

Vertical Panel Installation

Building paper or code-recognized weather-resistive barrier required behind siding

APA RATED SIDING panels. All edges supported by framing or blocking.

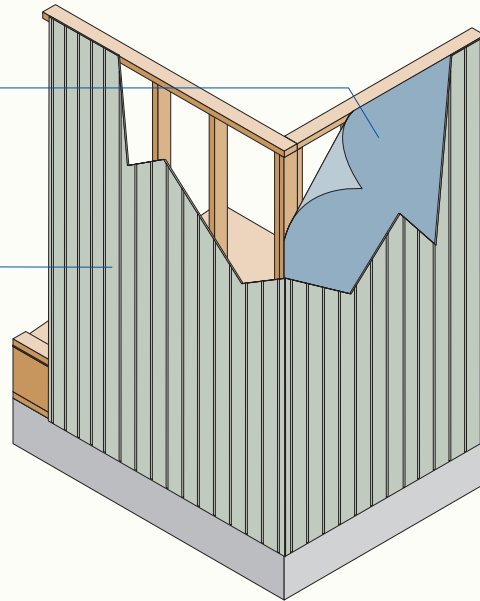

Horizontal Panel Siding Installation

Building paper or other code-recognized weather-resistive barrier

Battens at 4' or 8' o.c. to conceal butt joints at panel ends. Nails through battens must penetrate studs at least 1".

APA RATED SIDING panels (nailing as required for vertical installation)

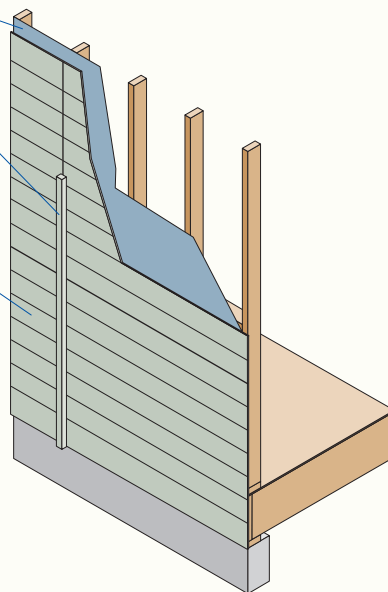

B**Back-Out**

See NAIL POPPING.

Back-Priming

Application of a coat of primer to the back of a panel. Cabinet doors should be back-primed to prevent warping.

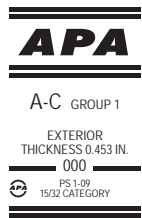
Backstamp

The approved agency mark on the back of a panel. Unsanded and touch-sanded panels, and most panels with A or B faces on one side only, carry the APA trademark on the panel back. See APA TRADEMARK and EDGEMARK.

Batten

A thin, narrow strip of plywood or lumber used to conceal or protect a joint between adjoining pieces of lumber or plywood.

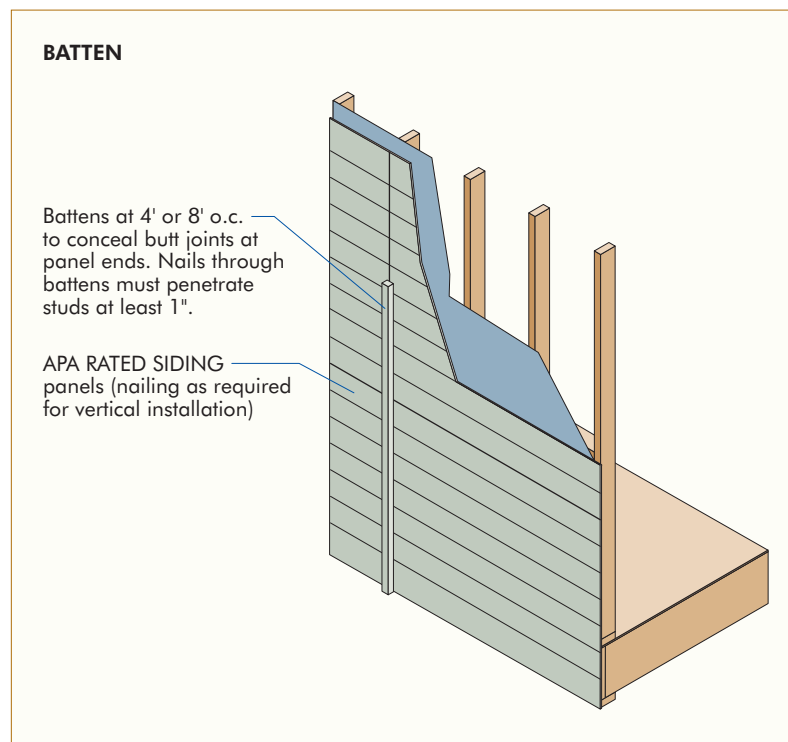

B-B

A sanded plywood panel with B-grade face and back and D-grade inner plies. Bond classification is Exposure 1. Utility panel for interior or protected applications.

B-B • G-2 • EXP 1 • 0.578 IN. • APA • 000 • PS 1-09 • 19/32 CAT

B-B Exterior

A sanded plywood panel with B-grade face and back and C-grade inner plies. Bond classification is Exterior. Utility panel with solid paintable surface both sides.

B-B • G-2 • EXT • 0.578 IN. • APA • 000 • PS 1-09 • 19/32 CAT

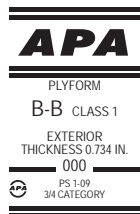
B-B Plyform®

Concrete form grades with high reuse factor. Sanded both sides and mill-oiled unless otherwise specified. Special restrictions on species. Also available in HDO for very smooth concrete finish, in STRUCTURAL I (all plies limited to Group I species) and with special overlays. Bond Classification is Exterior.

B-C Exterior

A plywood panel with sanded B-grade face, C-grade back and C-grade inner plies. Bond classification is Exterior. Utility panel for farm service and work buildings, boxcar and truck linings, containers, tanks, agricultural equipment, as a base for exterior coatings, etc.

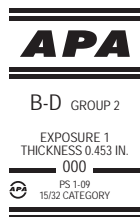
B-D

A plywood panel with sanded B-grade face, D-grade back and D-grade inner plies. Bond classification is Exposure 1. Utility panel for backing, sides of built-ins, industry shelving, slip sheets, separator boards, bins, etc.

Bevel

To cut panel edges or ends at an angle to make smooth mating joints between panels.

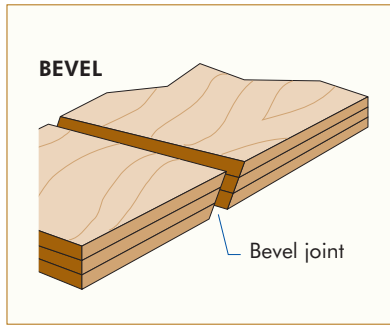
**Blocking**

Short lumber segments nailed between major framing members to support edges of structural panels where they meet.

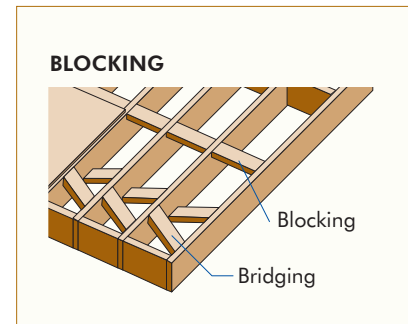
**Blow**

A localized delamination caused by steam pressure buildup during the hot pressing operation. The steam may result from high moisture content of the veneer or strands, excessive glue spread or high press temperatures.

Boat Patch

See REPAIRS.

Bond

To glue together, as veneers are “bonded” to form a sheet of plywood or a mat of strands to form OSB. Pressure is applied to keep mating parts in proper alignment. Glues used in panel manufacture require both heat and pressure to cure properly.

Bond Classification

Bond classification ratings for APA wood structural panels designated in APA trademarks as Exterior or Exposure 1.

Exterior panels have bonds capable of withstanding repeated wetting and redrying or long-term exposure to weather or other conditions of similar severity.

Exposure 1 panels are suitable for uses not involving long-term exposure to weather. Panels classified as Exposure 1 are intended to resist the effects of moisture on structural performance as may occur due to construction delays or other conditions of similar severity.

Bow

Distortion of a wood structural panel so that it is not flat lengthwise. See CUP.

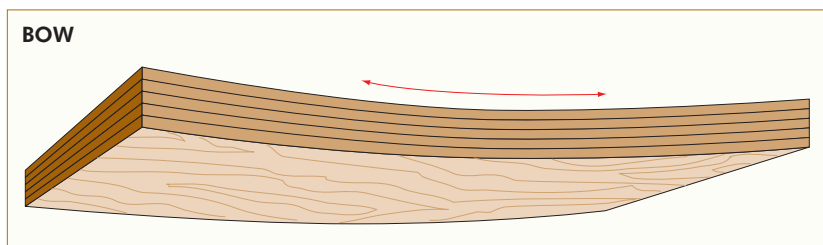

Box Beam

A beam built of lumber and wood structural panels in the form of a long hollow box which will support more load across an opening than will its individual members alone. Lumber members form the top and bottom (flanges) of the beam, while the sides (webs) are panels.

Bridging

Short wood or metal braces or struts placed crosswise between joists to help keep them in alignment. Bridging may be solid or crossed struts. See illustration under BLOCKING.

Brushed

An APA 303 Siding surface treatment. Brushed or relief-grain surfaces accent the natural grain pattern to create striking textures. Difficult to paint or stain. See APA RATED SIDING.

Bundle

A unit or stack of wood structural panels held together for shipment with bands. Stack size varies throughout the industry, with the average stack running about 30 to 33 inches high. A bundle 30 inches high, for example, contains 120 sheets of 1/4-inch panels, 80 sheets of 3/8-inch panels or 60 sheets of 1/2-inch panels.

Butt Joint

The joint formed when two parts are fastened together without overlapping. For end-to-end joints, use a nailing strip. For corner joints, nail directly into panel if it is at least 3/4 inch thick. If panel is thinner than 3/4 inch, use a reinforcing block.

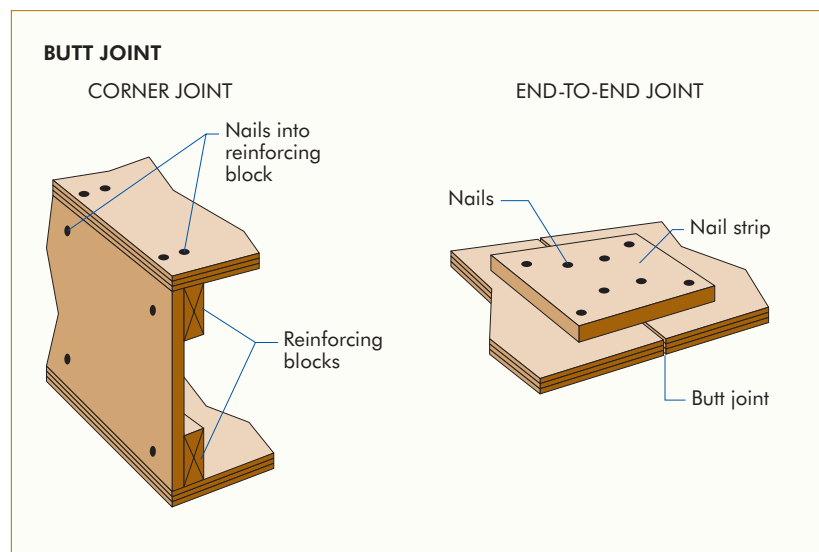
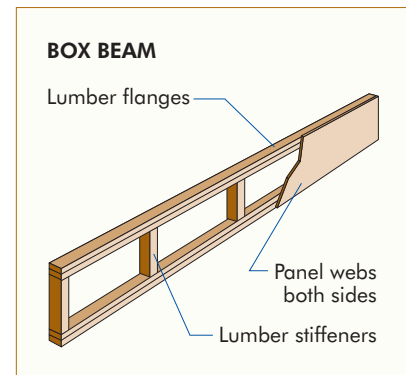

C

Caulk

Water-resistant sealant used to fill joints or seams. Caulks are available as putties, ropes or compounds extruded from cartridges.

C-C Plugged Exterior



A touch-sanded plywood panel with C-Plugged-grade face, C-grade back and inner plies. Bond classification is Exterior. Commonly used for severe moisture conditions, exterior balconies and decks, refrigerated or controlled atmosphere rooms, and boxcar and truck floors.

C-D Plugged

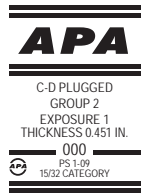

A touch-sanded plywood panel with C-Plugged-grade face, D-grade back and inner plies. Bond classification is Exposure 1. Used for built-ins, cable reels, walkways and slave pallets.

Center (Centers)

Inner ply or plies of a plywood panel whose grain runs parallel with that of the face and back plies.

Center Gap

See CORE GAP.

Center-To-Center

See ON-CENTER and CLEAR SPAN.

Chamfer

The flat surface created by slicing off the square edge or corner of a piece of wood or panel.

Channel Groove

An APA 303 Siding texture consisting of shallow grooves cut into panel faces during manufacture. See APA RATED SIDING.

Checking

Wood exposed to alternating moist and dry conditions eventually develops open cracks or “checks.” Reduce checking by sealing panel edges before installation to minimize moisture absorption and by using an elastomeric priming coat or resin sealer on the surfaces.

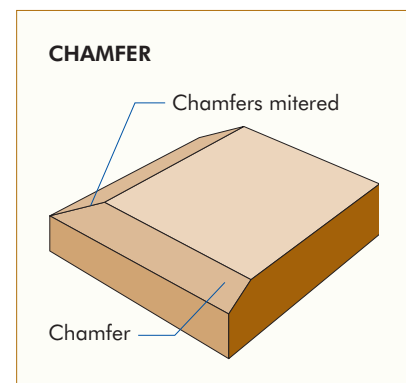

Chord

Any of the outside members of a truss connected by web members. Also, may refer to perimeter members of a panel diaphragm. See illustration under TRUSS.

Circular Plug

See REPAIRS.

Class I

See B-B PLYFORM.

Clear Span

Distance between inside faces of supports.

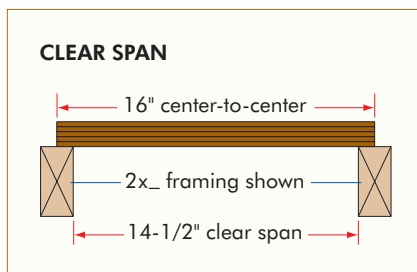
**Code**

See MODEL CODE.

COM-PLY®

APA proprietary trade name for APA member-produced composite panels. See APA PERFORMANCE RATED PANELS and COMPOSITE PANEL.

Component

A glued and/or nailed structural assembly of wood structural panels and lumber, such as a stressed-skin panel. Also describes prefabricated building sections in panelized construction.

Composite Panel

A veneer-faced panel with a reconstituted wood core. See APA PERFORMANCE RATED PANELS and COM-PLY.

Concentrated Load

See LOADS.

Concrete Form

Mold into which fresh concrete is placed to set. Plywood provides tough, durable, easy-to-handle, split-resistant and lightweight concrete forms. It can be bent for curved forms and liners, and its natural insulating properties help moderate temperature variations for more consistent curing. Almost any APA trademarked plywood can be used in concrete formwork applications, but PLYFORM is specifically manufactured for that purpose. See B-B PLYFORM.

Core (Cores)

In conventional plywood, inner plies whose grain runs perpendicular to that of the outer plies. See PLY.

Core Gap (Center Gap)

An open veneer joint extending through or partially through, a plywood panel. Product Standard PS 1 specifies that the average of all gaps shall not exceed 1/2 inch, and that every effort be made to produce closely butted core joints.

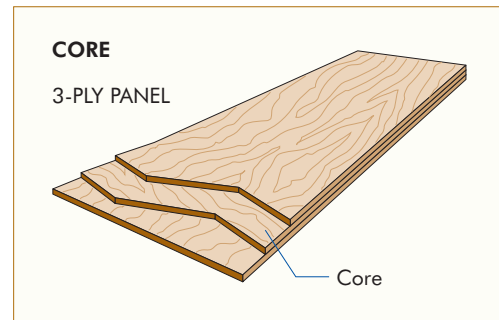

Crawl Space

A space often about two feet high beneath a house floor allowing access to plumbing or wiring. See PIRF.

Cripple

Any vertical framing member cut less than full length, as in cripple studs under a window opening.

Crossband (Cores)

In plywood, the veneer layers with grain direction perpendicular to that of the face plies. See CORE.

Cross Laminated Timber (CLT)

A prefabricated solid engineered wood panel made from at least three layers of solid-sawn lumber or structural composite lumber (SCL) that are stacked crosswise and bonded together with structural adhesives to form a solid, rectangular-shaped panel that is intended for construction applications, including roofs, floors and walls in residential and nonresidential buildings. Orthogonally bonding the layers increases the structural and dimensional stability of the product as a slab or wall.

Cross Cutting

Sawing wood across the grain. Because the wood in wood structural panels is either cross-laminated or randomly oriented, any cut made in a wood structural panel is a cross cut. Always use a cross-cut saw when hand- or power-sawing wood structural panels.

Cup

Crosswise distortion of a wood structural panel from its flat plane. See BOW.

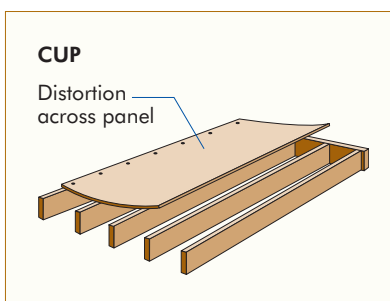

Curved Panel

Stressed-skin or sandwich panels curved to various degrees of arc. Used in roof construction.

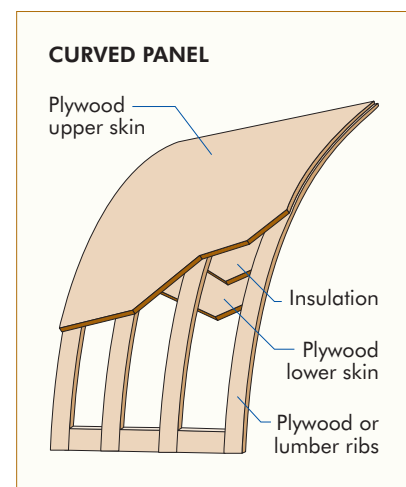

D

Dado Joint

Joint formed by intersection of two boards, one of which is notched with a rectangular groove.

Dead Load (D.L.)

See LOADS.

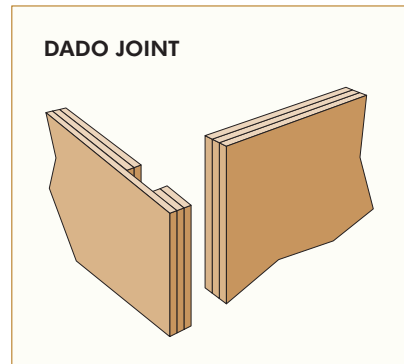

Decorative Panel



A plywood panel grade with rough-sawn, brushed, grooved or striated faces. May have bond classification of Exterior or Exposure 1. Common uses include paneling, built-ins, accent walls, counter facings and displays. Exterior uses include siding, gable ends and fences. Check with manufacturer for specific Exterior application recommendations, which vary with particular products.

Deflection

Bending of a wood structural panel or framing member between supports under an applied load.

Delamination

Separation between plies or within reconstituted wood due to adhesive bond failure. Separation in area immediately over or around a permitted defect does not constitute delamination.

Diaphragm

Elements of a building that provide shear strength to withstand wind and earthquake loads.

Dogbone Plug

See REPAIRS.

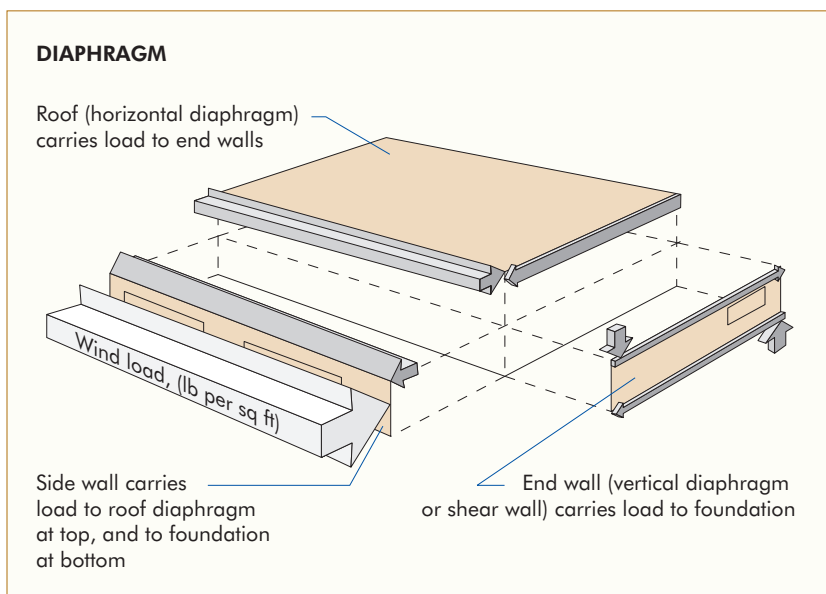

Double Wall

A light frame wall construction system consisting of exterior finish siding, such as APA RATED SIDING, applied over structural wall sheathing – typically APA RATED SHEATHING. See APA STURD-I-WALL.

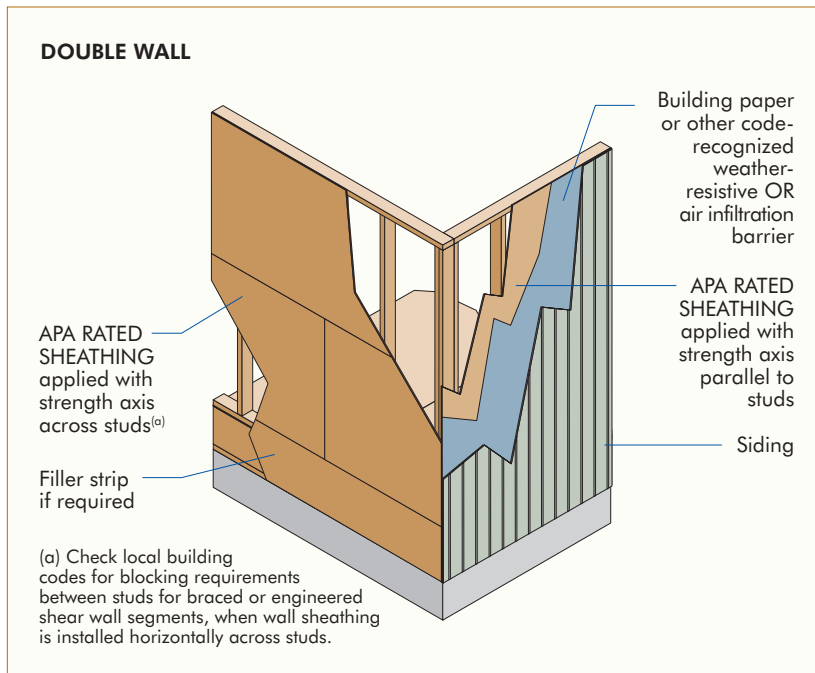

E

Eave

The edge of a roof that extends beyond or overhangs a wall. The underside of an eave may form an “open soffit.” Textured panels, applied face down to eave rafters as roof sheathing, give open soffits a decorative finished surface. See SOFFIT.

Edgemark

APA trademark stamped on the panel edge. Appears on sanded grades with B-grade or better veneer faces, PLYRON, MARINE and panels with overlaid surfaces on both sides.

A-B • G-1 • EXP 1 • 0.234 IN. • APA • 000 • PS 1-09 • 1/4 CAT

Edge Sealing

Application of a coating (e.g., sealant, paint) to the edges of a wood structural panel to reduce its water absorption. Edge seal before painting the panel surface if panel edges will be exposed to repeated wetting and drying.

Edge Spacing

See PANEL SPACING.

Edge Support

Support, such as panel clips or lumber blocking, installed between framing members at wood structural panel edges to transfer loads from one panel to the other across the joint. Panels with tongue-and-groove edges can be used in many applications without additional edge support.

Edge Treatment

Edge finishing method, such as banding with wood or plastic, or filling with putty or spackle.

Edge Void

A panel defect in which the edge or end of an inner ply has split or broken away during manufacture, leaving a gap in the edge of the plywood panel.

Embossed

A panel surface treatment. Heat and pressure against a master pattern impress a variety of textured effects into panel surfaces, which remain smooth and paintable.

End Grain

The end of a piece of wood exposed when the wood fibers are cut across the grain. All wood structural panel edges are end grain, and should be finished accordingly.

End Spacing

See PANEL SPACING.

EDGE TREATMENTS

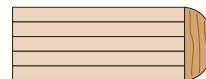

Bull nose edging. Keep edges rounded; use matching strip of rounded solid wood.

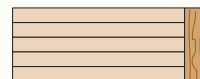

Butt edging. Keep edges square; use matching strip of solid wood.



“Mitered” butt edging. Use glue and brads to fasten strips.

Engineered 24" Framing

A building system using wood structural panels over lumber framing spaced 24 inches on center in walls, floors and roof. The system's series of in-line frames – trusses, studs and joists – provide cost-effective materials utilization and simpler, faster construction. It is recognized by major model codes.

Engineered Wood Products

Structural wood products manufactured by bonding together wood strands, veneers, lumber or other forms of wood fiber to produce a larger and integral composite unit with superior performance characteristics. These high performance building components achieve predictable and reliable performance characteristics with the efficient use of natural resources.

Expansion

Moisture absorption causes wood to expand. Spacing between panel edges and ends is recommended to allow for any possible panel swelling. See PANEL SPACING.

Exposure 1

See BOND CLASSIFICATION.

Exterior

PS 1 exposure bond classification term for plywood manufactured for permanent outdoor or marine use. See BOND CLASSIFICATION.

F

Face

The highest-grade side of any veneer-faced panel that has outer plies of different veneer grades. Also, either side of a panel where grading rules draw no distinction between faces. For example, the face of an A-C panel is the side with the A-grade outer ply. Both sides of an A-A or B-B panel are referred to as faces.

Face-Checking

Partial separation of wood fibers parallel to grain in the wood or veneer surfaces of panels caused chiefly by the strains of weathering and seasoning. See CHECKING.

Face Grain

Direction of the grain of the outer ply (face) of a veneer-faced panel in relation to its supports. A panel's greatest stiffness and strength is parallel to the face grain. Therefore, in construction, run the face grain or long dimension of the panel across supports for greatest stiffness and strength.

Fascia

Wood or plywood trim used along the eave or the gable end of a structure.

Fiber-Reinforced Plastic (FRP)

A tough, scuff-resistant panel coating made of glass or other fibers combined with resins. These coated panels (composite) are used in truck and trailer bodies, containers and concrete forms. Seamless panels 40 feet long and longer can be produced as trailer sidewalls or roofs. Or, a very strong strip of glass or other fibers and resin that is applied to bottom of glulam timbers to increase the strength and stiffness properties of the glulam beam.

Filler

A material for filling nail holes, checks, cracks or other blemishes in surfaces of wood before application of paint, varnish or other finishes.

Finishes

Stains, paints or sealers which protect, color or enhance the natural beauty of wood structural panels.

Exterior finishes primarily protect siding and maintain its appearance. They minimize the weathering action which roughens and erodes the surface of unfinished wood. Different finishes give varying degrees of protection so the type, quality, quantity and application must be considered to achieve the desired performance. All exterior panel edges should be sealed if the panels will be painted or stained. Sealing while panels are stacked is easiest. Exterior finishes recommended for wood structural panels include semi-transparent stain, solid-color stain and acrylic latex paint.

Interior finishes: Preparation is minimal. Overlaid (MDO and HDO) plywood needs no preparation; sanded and textured grades require only touch-sanding. Recommended interior finishes include oil base paint, latex paint, stain and sealer.

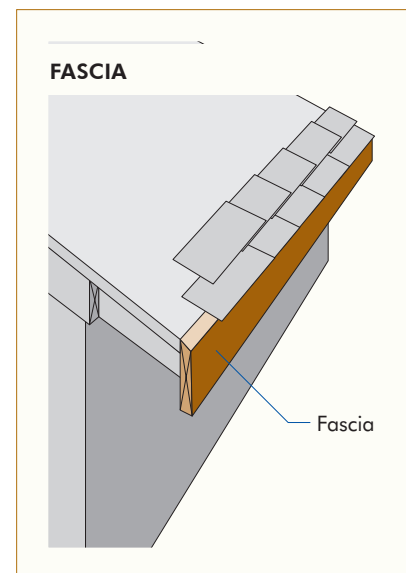

Fire-Rated Systems

Wall, floor and roof construction of specific materials and designs that has been tested and rated according to fire safety criteria (e.g., flame spread rate and fire resistance). Testing and approval are performed by agencies such as Underwriters Laboratories, Inc. A one-hour rating, for example, means that an assembly similar to that tested will neither collapse nor transmit flame or high temperature for at least one hour after a fire starts. Structural wood panels are an approved material in a number of fire-rated designs. See FLAME SPREAD.

Fire-Retardant-Treated (FRT)

Chemical treatment of wood and plywood to retard combustion. Plywood is pressure-impregnated with fire retardant chemicals mixed in water in accordance with American Wood Protection Association (AWPA) Standards U1 and T1. NOTE: Span Ratings and load capacities are based on untreated panels, and may not apply following fire-retardant treatment. Obtain structural performance characteristics of FRT panels from the company providing the treatment and redrying service.

Flame Spread

The spread of fire along the surface of a material. Flame spread ratings are expressed in numbers or letters and are used in building code interior finish requirements.

Flange

Top and bottom longitudinal members of a beam. Box beams and I-joists are fabricated with lumber or engineered wood flanges (top and bottom) and wood structural panel webs (sides). See BOX BEAM and I-JOIST.

Flashing

See Z FLASHING.

Foam Core

Center of a wood structural panel-faced “sandwich” panel. Liquid plastic foamed into all spaces between the panels serves to both insulate and support the component skins. Or wood structural panel skins are pressure-glued to both sides of rigid plastic foam boards or billets. See SANDWICH PANEL and STRUCTURAL INSULATED PANEL.

Footing

The base for foundation walls, posts, chimneys, etc. The footing is wider than the member it supports, and distributes the weight of the structure to the ground over a larger area to prevent settling.

Formaldehyde

Formaldehyde is a naturally occurring, organic molecule that can be irritating at high concentrations. It is true that some adhesives are known to emit formaldehyde. But engineered wood products are made with moisture-resistant adhesives that are associated with very low emission rates.

FRP

See FIBER-REINFORCED PLASTIC.

FRT

See FIRE-RETARDANT-TREATED.

Frame Construction

See LIGHT-FRAME CONSTRUCTION.

Furnish

Wood-based material such as flakes or strands, including additives, such as adhesive and wax, used to manufacture OSB.

Furring

Process of leveling parts of a ceiling, wall or floor by means of wood strips, called furring strips, before adding panel cover.

G

Girder

A large horizontal beam which supports interior walls or joists. Most wood frame houses have a lengthwise center girder that supports the joists and floor panels. Girders can be timber or engineered wood. See LIGHT-FRAME CONSTRUCTION.

Glue

See ADHESIVE.

Glue-Nailed (Nail-Glued)

Gluing wood structural panel joints and connections with pressure provided by nailing. For most effective fastening, pieces should meet continuously along their joint. Apply glue to one or both surfaces according to manufacturer's directions, then press surfaces together and nail in place. For work such as cabinets or drawers, or whenever possible, joint should be clamped as well as nailed to maintain pressure until glue sets.

Glued Floor System

See APA GLUED FLOOR SYSTEM.

Glueline

The adhesive joint formed between veneers in a plywood panel or between face veneers and core in a composite panel (**primary glueline**), or between lumber and wood structural panel parts in an assembly such as a component (**secondary glueline**).

Glulam

Short for structural glued-laminated timber – large beams fabricated by bonding layers of specially selected lumber with strong, durable adhesives. End and edge jointing permit production of longer and wider structural wood members than are normally available. Glulam timbers are used for many types of residential and commercial construction.

Grade

Refers to the letter-graded quality of veneers used in plywood manufacture (N, A, B, C-Plugged, C and D) or to particular panels, e.g., A-A, Underlayment, etc. See also VENEER GRADE.

Grain

The natural growth pattern in wood. The grain runs lengthwise in the tree and is strongest in that direction. Similarly, grain usually runs the long dimension in a panel of plywood or OSB, making it stronger in that direction. Wood structural panels should therefore usually be applied with the long dimension perpendicular to (across) supports.

Grain Raise

The condition on the surface of a plywood panel resulting from harder or denser wood fibers swelling and rising above softer surrounding wood.

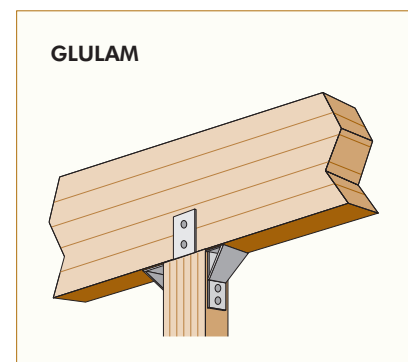

Groove

One of the surface treatments frequently given to textured siding in which a series of narrow, parallel channels are cut into the surface of the panel. Grooving is available in a variety of widths and spacings on several surface textures. See APA RATED SIDING and TONGUE-AND-GROOVE JOINT.

Group Number

Plywood is manufactured from over 70 species of softwood. These species are classified according to strength and stiffness under manufacturing standard PS 1 into Groups 1 through 5. Group 1 woods are the strongest. The group number of a particular panel is determined by the weakest (highest numbered) species used in face and back (except for some thin panels where strength parallel to face grain is unimportant).

Growth Ring

A tree's annual cross-sectional growth layer, including springwood and summerwood.

Gusset Plate

A piece of wood structural panel connecting lumber members of a truss or other frame structure. Gussets may be applied to one or both sides of the joint. Plywood or OSB are used because of their great strength and split-resistance. Commonly used for repairs of metal-plate-connected wood trusses.

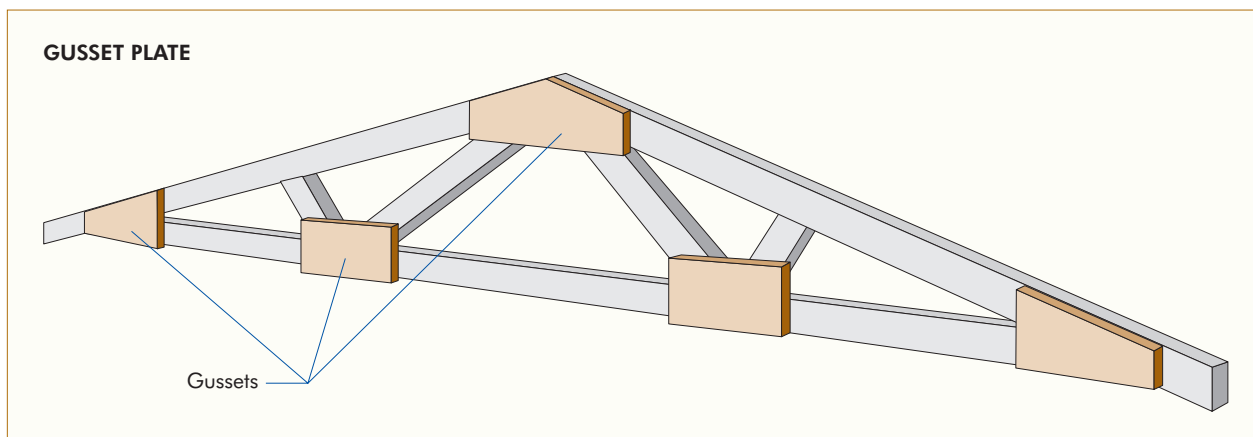

H

Hardwood

Wood of the deciduous or broadleaved trees – oak, maple, ash, walnut – as distinct from the softwood of the coniferous or needleleaved trees – pine, fir, spruce, hemlock. The term has only a general reference to actual wood hardness. Construction and industrial plywood may use either variety. See **SOFTWOOD**.

HDO

See **HIGH DENSITY OVERLAY**.

Header

A cross member, solid-sawn or engineered wood, placed between studs or joists to support loads over openings for stairways, chimneys, doors, etc. See **FRAME CONSTRUCTION**.

Heartwood

The nonactive core of a tree, often distinguishable from the growing sapwood by its usually darker color and greater resistance to rot and decay.

Heavy Timber

A building code designation for a particular type of construction (Type IV) with good fire endurance. Heavy Timber is widely recognized as comparable to one-hour construction. A panel roof deck of 1-1/8-inch tongue-and-grooved plywood with exterior bond classification over 4-inch-wide supports meets the Heavy Timber requirements and provides the same fire performance as nominal 2-inch tongue-and-groove lumber decking.

High Density Overlay (HDO)

Plywood finished with a resin-impregnated fiber overlay to provide extremely smooth hard surfaces that need no additional finishing and have high resistance to chemicals and abrasion. The overlay material is bonded to one or both sides of the plywood as an integral part of the panel faces. Used for concrete forms, cabinets, highway signs, counter-tops and other punishing applications. See **MEDIUM DENSITY OVERLAY (MDO)**.

I-Beam

See I-JOIST.

Identification Index

Former term for Span Rating. See SPAN RATING.

IIC

See IMPACT INSULATION CLASS.

I-Joist

Joist whose cross section resembles the letter “I.” The flanges of an I-joist are composed of lumber or laminated veneer lumber (LVL), and the web is composed of plywood or oriented strand board.

Impact Insulation Class (IIC)

Values which rate the capacity of floor assemblies to control impact noise such as footfalls. FHA requirements (and some local building codes) specify minimum acceptable ratings.

Impact Noise Rating (INR)

Values for floor assembly impact sound transmission, now replaced by IIC classification.

Inner Plies

All plies of a plywood panel except face and back.

INR

See IMPACT NOISE RATING.

International Code Council – Evaluation Service

ICC-ES is one of a number of organizations that studies applications for new proprietary products that fall outside the scope of the model code. Evaluation reports are then issued that indicate product equivalency to specific sections of the code. See MODEL CODE.

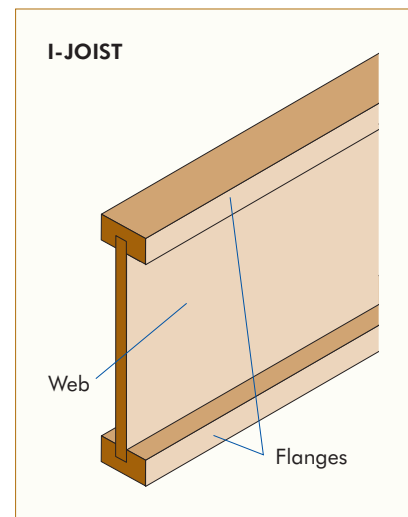

J

Jointed Core

Core veneer that has had edges machined square. Gaps between pieces of core shall not exceed 3/8 inch, and the average of all gaps in the panel shall not exceed 3/16 inch.

Joist

Horizontal framing member of a floor, ceiling or flat roof. Wood structural panels are commonly used for subflooring and underlayment or single-layer flooring (APA RATED STURD-I-FLOOR) over floor joists. APA RATED SHEATHING is typically used over roof joists.

K

Kerf

A slot made by a saw; the width of a saw blade cut.

Kiln-Dried

Wood dried in heated chambers (kilns) by controlled heat and humidity used to dry solid wood to specified limits of moisture content. Veneers are dried before lay-up in similar chambers. See SEASONING.

Knot

Natural growth characteristic of wood caused by a branch base imbedded in the main tree stem.

Knothole

Void produced when a knot drops out of veneer.

L

Laminated Strand Lumber (LSL)

A composite of wood strand elements with wood fibers primarily oriented along the length of the member, where the least dimension of the wood strand elements is 0.10 inch (2.54 mm) or less and their average lengths are a minimum of 150 times the least dimension of the wood strand elements. LSL is one of several structural composite lumber (SCL) types. See SCL for more information.

Laminated Veneer Lumber (LVL)

A composite of wood *veneer* sheet elements with wood fibers primarily oriented along the length of the member, where the *veneer* element thicknesses are 0.25 inch (6.4 mm) or less. LVL is one of several structural composite lumber (SCL) types. See SCL for more information.

Lap

To position adjacent objects so that one surface extends over the other. Term may designate a **lap siding** technique, in which each panel or piece overlaps the edge of the next lower panel. A **shiplap joint** unites two panels when half the thickness of each is cut away so that the two pieces fit together with outer faces flush.

Layer

In plywood, a layer consists of one or more adjacent plies having the wood grain in the same direction. For instance, four-ply panels always have three layers with both core plies at right angles to the faces. The two core plies are one layer and each face is a layer. In composite panels, the reconstituted wood portion is one layer and each face is a layer. See PLY, ORIENTED STRAND BOARD.

Lay-Up

The step in wood structural panel manufacture in which veneers or reconstituted wood layers are “stacked” in complete panel “press loads” after gluing and before pressing. Also the construction of the panel.

Light-Frame Construction

Construction in which the structural parts are wood or dependent on a wood framework for support. Typically, lumber framing is sheathed with wood structural panels for roofs, walls and floors. The classification of light-frame construction remains the same in building codes even when masonry covering is applied on exterior walls.

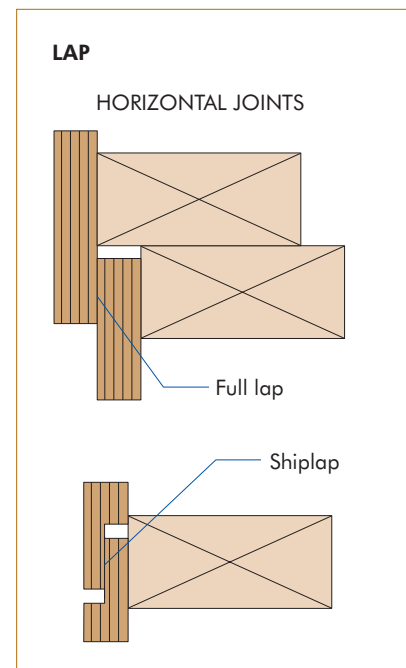

LIGHT-FRAME CONSTRUCTION

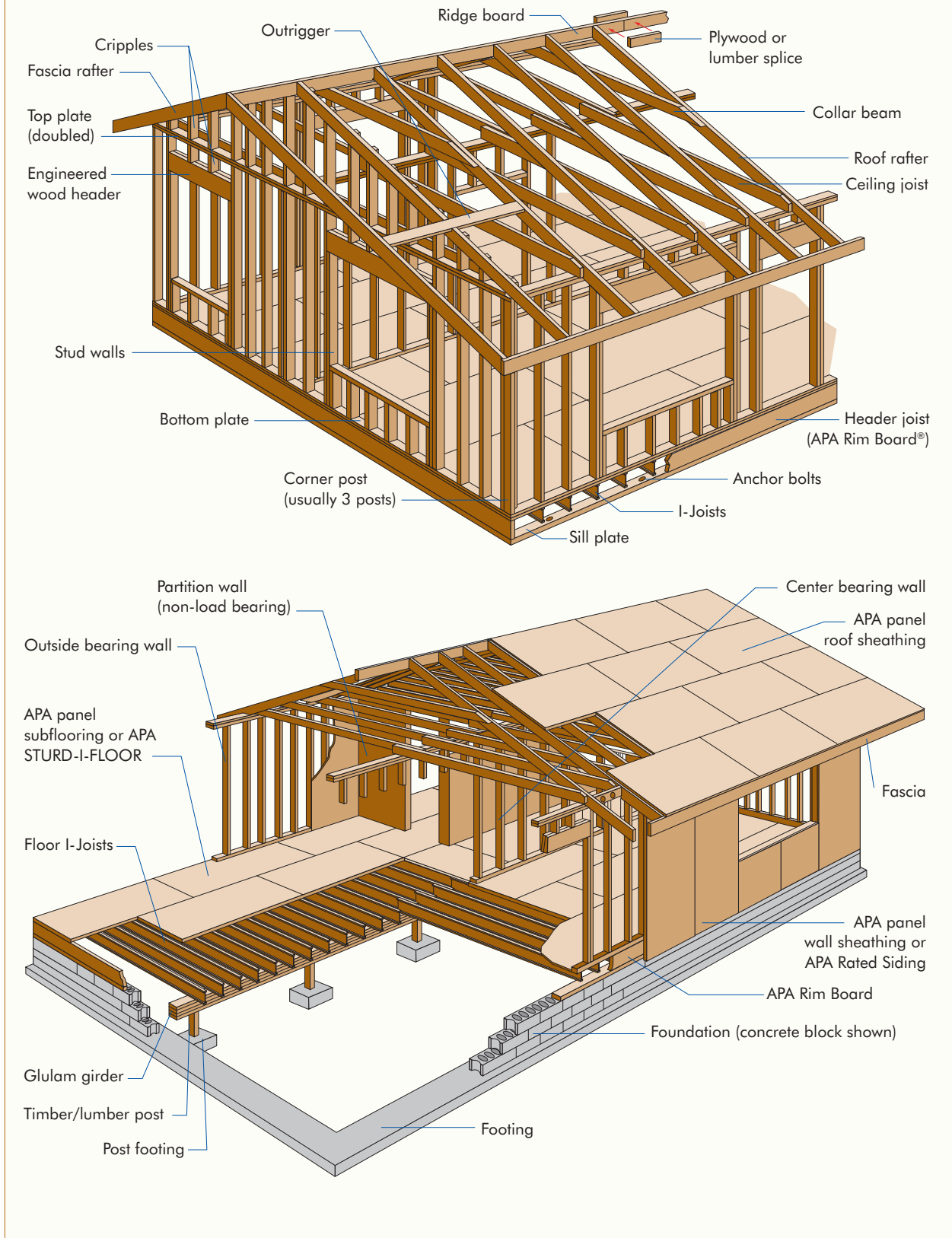

Live Loads (L.L.)

See LOADS.

Loads

The weight or pressure a structure carries or sustains, which must be considered in building design. **Uniform loads** are evenly distributed over a large area, usually the entire surface of a panel. **Concentrated loads** are applied over a very small area (for example, by a piano leg). **Dead loads** are stationary, permanent loads; that is, the weight of all the material used in construction of the building (or section). **Live loads** are planned loads the structure must carry under normal conditions, such as people or furniture and equipment, that would be moved across the structure's surface. These loads are generally assigned by the building code for the type of structure; for example, a heavy-equipment storage warehouse, a house or an office building. Live loads are generally considered to be uniform loads. **Environmental loads** include wind, snow and earthquake.

Lumber Core

Plywood manufactured with a core composed of lumber strips. The face and back (outer) plies are veneer.

M

Marine Grade

Plywood panels manufactured with the same glue-line durability requirements as other Exterior panels but with more restrictive veneer quality and manufacturing requirements. The grade is particularly suitable for marine applications where bending is required, as in boat hulls.

MARINE • A-A • EXT • 0.609 IN. • APA • 000 • PS 1-09 • 5/8 CAT

MDO

See MEDIUM DENSITY OVERLAY.

Medium Density Overlay (MDO)

The resin-treated kraft paper applied to a panel or panels finished with an opaque resin-treated fiber overlay to provide a smooth surface ideal as a paint base. Recommended for siding and other outdoor applications, and for built-ins, signs and displays, furniture, etc. May be applied to one or both faces of the panel. Available without grooving, with V-grooves, in T 1-11 or reverse board-and-batten grooving. See HIGH DENSITY OVERLAY (HDO) and APA RATED SIDING.

Miter Joint

A joint formed by fitting together two pieces of lumber or panels that have been cut at a 45° angle.

Model Code

A building code developed by the International Code Council (ICC), such as the International Building Code (IBC) and International Residential Code (IRC). These are continually reviewed and updated by committees of building officials with input from industry, academia and users.

Moisture Retarder

See VAPOR RETARDER.

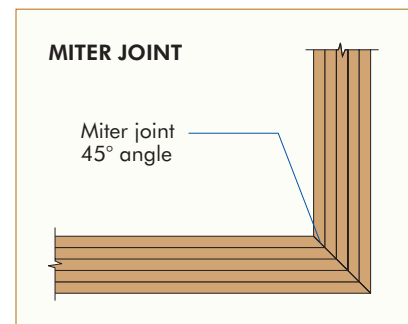

N

Nails

Nails commonly used for residential construction include:

Common and box nails: 16 penny (d) common and box, for general framing. 8d and 10d common and box nails, for toenailing. 6d and 8d common and box nails, for subfloor, wall and roof sheathing. Size depends on thickness of wood structural panel sheathing.

Scaffold nails: 8d and 10d most common, for scaffolds, bracing and any temporary fastening that must later be removed.

Siding nails: Nonstaining nails of size specified for siding thickness.

Casing and finish nails: 4d, 6d and 8d most common, for exterior and interior trim and installation of siding and paneling where large nailheads should not show.

Roofing nails: A special type, commonly available. Size depends on thickness of roofing and deck material.

Drywall nails: 4d to 6d size depends on drywall thickness; for 1/2-inch drywall use 4d drywall nails.

For underlayment and finish floor: Special nail types with greater holding power than ordinary varieties are also available. For hardwood strip flooring, use either 8d hardwood nails or 2-1/2-inch hardened, spiral-threaded (screw-shank) nails. For 1/2-inch and thinner Underlayment grade plywood (over subflooring), use 3d ring-shanks. For 19/32 through 3/4-inch Sturd-I-Floor panels, use any of the 4d deformed-shank nails illustrated at right.

For 1/4-inch panels use 3/4-inch or 1-inch brads, 3d finish nails, or (if no objection to heads showing) 1-inch blue lath nails. For exterior application, use galvanized or coated nonstaining nails or fasteners.

Predrilling is occasionally necessary in careful work where nails must be very close to panel edges. Select a drill bit of slightly smaller diameter than the nail to be used.

Space nails about 6 inches apart for most work. Closer spacing is necessary only with thin panels which might otherwise buckle slightly between nails.

Nail-Glued

See GLUE-NAILED.

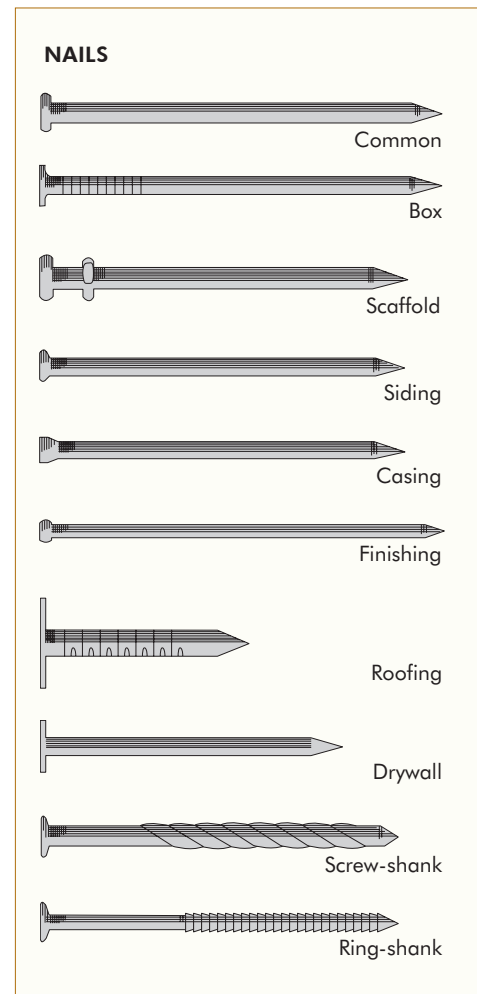

Nail Popping

Flooring nails occasionally appear to “pop” up so that nail head impressions are visible on the surface of the finished floor covering. Shrinkage of floor joist away from the nail shank after installation exposes the head. When floor members are dry, make sure fasteners are flush with or below floor surface just prior to installation of thin floor covering such as tile, linoleum or vinyl. Fasteners should be set if green framing will present nail popping problems upon drying. **Do not fill nail holes.**

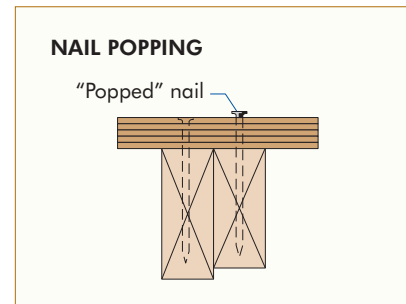

Nail Sizes

The appropriate lengths and wire sizes of various nail penny sizes are listed at right.

Noise-Rated Systems

Construction designed to reduce sound transmission. Various wood structural panel construction systems tested both in laboratories and buildings meet or exceed requirements.

Nominal Dimension

Full “designated” dimension. For example, a nominal 2-inch by 4-inch stud measures 1-1/2 inch x 3-1/2 inch when surfaced. It is a commercial size designation, subject to acceptable tolerances. See SIZED FOR SPACING.

NAIL SIZES (ASTM F1667)

Penny Size (d)	Type	Length (in.)	Wire Diameter (in.)
3d	Ring- or screw-shank	1-1/4	0.099*
4d	Finish	1-1/2	0.072
	Box and casing	1-1/2	0.080
	Ring- or screw-shank	1-1/2	0.099*
6d	Finish	2	0.092
	Box and casing	2	0.099
	Siding	1-7/8	0.106
	Common	2	0.113
	Ring- or screw-shank	2	0.120*
8d	Finish	2-1/2	0.099
	Box and casing	2-1/2	0.113
	Siding	2-3/8	0.128
	Common	2-1/2	0.131
	Ring- or screw-shank	2-1/2	0.120* or 0.131*
10d	Box and casing	3	0.128
	Common	3	0.148
16d	Box and casing	3-1/2	0.135
	Common	3-1/2	0.162
	Sinker	3-1/4	0.148

*International Staple, Nail and Tool Association (ISANTA) ESR-1539, www.icc-es.org

Noncertified

Structural panels not included in Product Standard PS 1, PS 2 or covered under various other Performance Standards, and which may bear the mark of the manufacturer rather than a recognized testing agency, such as APA.



O & ES

Oiled and edge-sealed. Surfaces of concrete form panels are lightly coated with oil and the edges sealed **if** specified.

On-Center (O.C.)

On-center spacing, meaning the distance from the center of one structural member to the center of the adjacent member, as in the spacing of studding, joists, rafters, nails, etc. See CLEAR SPAN.

Open Defects

Irregularities such as splits, open joints and knotholes that interrupt the smooth continuity of veneer.

Oriented Strand Board (OSB)

Wood structural panels manufactured from reconstituted, mechanically oriented wood strands bonded with adhesive under heat and pressure. Oriented strand material may be produced as the center layer of composite panels or may be cross-laminated in layered panels. See APA PERFORMANCE RATED PANELS.

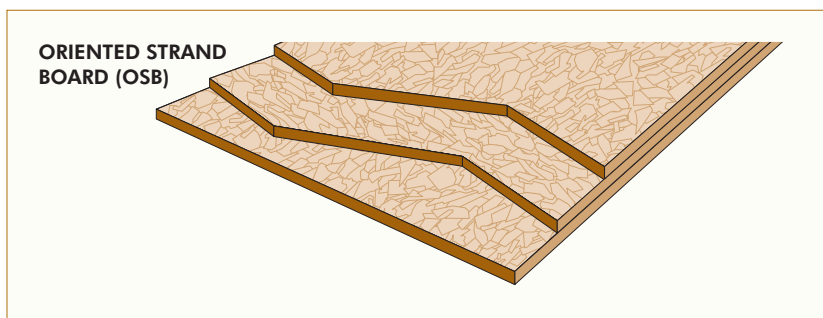

Oriented Strand Lumber (OSL)

A composite of wood strand elements with wood fibers primarily oriented along the length of the member, where the least dimension of the wood strand elements is 0.10 inch (2.54 mm) or less and their average lengths are a minimum of 75 times and less than 150 times the least dimension of the wood strand elements. OSL is one of several structural composite lumber (SCL) types. See SCL for more information.

Over-Driven Nails

Nails placed such that the head of the nail breaks the surface of the panel product. Over-driven nails reduce the lateral and nail-head pull-through capacity of the nailed connection and are not considered good practice.

Overlaid Plywood

Plywood panels with factory-applied, resin-treated fiber faces on one or both sides. Term may also apply to metal and other overlaid panels. See HIGH DENSITY OVERLAY (HDO) and MEDIUM DENSITY OVERLAY (MDO).

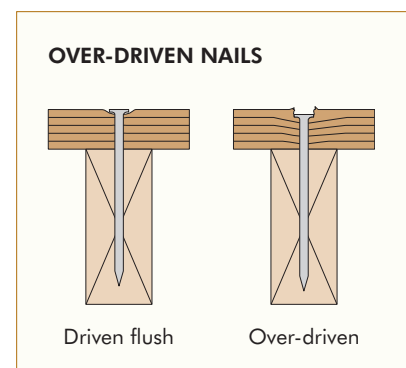

P

P & TS

Plugged and touch-sanded face of a plywood or composite panel.

Paints

See FINISHES.

Panel Clip

Specially shaped metal device for supporting panel edges to reduce differential deflection in roof construction.

Panel Performance Category

A recent emphasis on compliance with the Weights and Measures of the National Institute of Standards and Technology has led to the designation of *Performance Category* in lieu of *nominal panel thickness* for wood structural panels. As an example, a panel formerly identified as *3/8-inch thickness*, is now designated as *3/8 Performance Category*. This change has no impact on the design values, use recommendations and qualification or manufacturing requirements of the wood structural panels. See APA RATED SHEATHING and APA RATED STURD-I-FLOOR.

Panel Spacing

The gap left between installed panels in a structure. Panels in floor, wall or roof deck construction should be spaced to allow for any possible expansion due to changing moisture absorption levels. Proper spacing helps prevent buckling and warping. APA spacing recommendations are shown in the table at right. See SIZED FOR SPACING.

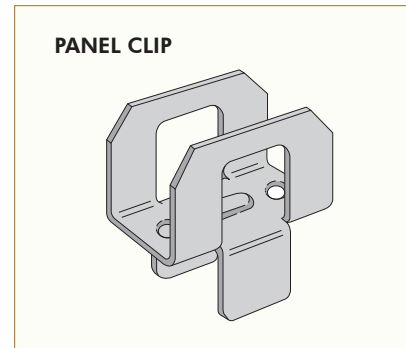

Panel Type	Edge	End
APA Rated Sheathing	1/8	1/8
APA Rated Siding	1/8	1/8
APA Rated Sturd-I-Floor	1/8	1/8
Underlayment	1/32	1/32

Paneling

Wood panels joined in a continuous surface, especially decorative panels for interior wall finish. Textured plywood in many varieties is often used as interior paneling either in full wall sections or accent walls. See APA RATED SIDING for textured plywood used as paneling.

Panelized Construction

Building components fabricated in wall, floor or roof sections, etc., to be assembled into a completed structure at the building site. Panelized construction speeds erection and cuts on-site labor costs. It offers the high quality available through controlled factory production and inspection procedures.

Parallel Strand Lumber (PSL)

A composite of wood strand elements with wood fibers primarily oriented along the length of the member where the least dimension of the wood strand elements is 0.25 inches (6.4 mm) or less and their average lengths are a minimum of 300 times the least dimension of the wood strand elements. PSL is one of several structural composite lumber (SCL) types. See SCL for more information.

Patch

See REPAIRS.

PCUF

See PLUGGED CROSSBAND UNDER FACE.

Peeler Log

A specially selected log used to produce veneer. Peelers are debarked, then lathe-turned against a long knife blade which slices off a thin, continuous ribbon of veneer then clipped to size, dried, graded, repaired and laminated into plywood panels or LVL billets.

Performance Rated Panels®

See APA PERFORMANCE RATED PANELS.

Performance Standard

A standard applying to panels such as APA RATED SHEATHING, APA RATED STURD-I-FLOOR and APA RATED SIDING. Panels manufactured to meet APA performance standards must satisfy rigorous, exacting performance criteria. See PRODUCT STANDARD and APA PERFORMANCE RATED PANELS.

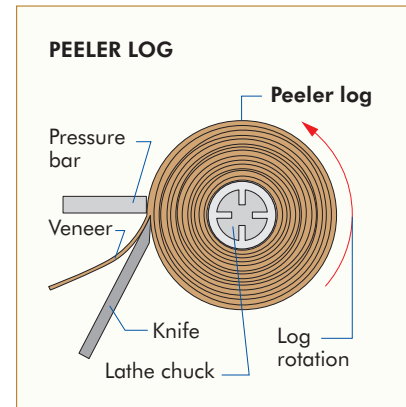
**Permanent Wood Foundation**

See WOOD FOUNDATION.

PIRF (Perimeter-Insulated Raised Floor System)

Crawl space foundation-floor system where insulation is applied only to the inside of the perimeter foundation stem wall. The resulting system saves construction costs and gives superior energy performance.

Pitch Streak

A localized accumulation of pitch in wood cells in a more or less regular streak.

Plate

In wood frame construction, the horizontal lumber member on top and/or bottom of the wall studs which ties them together and supports the studs or rafters.

Plug

See REPAIRS.

Plugged Core

Inner ply construction of C-Plugged veneer pieces. Gaps between pieces of core should not exceed 1/2 inch per Product Standard PS 1. See JOINTED CORE.

Plugged Crossbands Under Face (PCUF)

A designation denoting a PANEL of special construction, making it suitable for use as an UNDERLAYMENT, for example A-C (PCUF).

Ply

A single veneer in a panel.

Plyform

See B-B PLYFORM.

Plyron®

A plywood panel manufactured with a hardboard face for an extra-smooth painting and tough wearing surface. May be Exposure 1 or Exterior. Exposure 1 PLYRON is available with a standard, tempered or treated hardboard surface and is manufactured of D-grade veneer except the ply directly under the hardboard surface, which must be C-grade. Exterior PLYRON is available with a tempered or treated surface and is manufactured with C-grade plies throughout. PLYRON is ideal for work surfaces, fixtures, built-ins, cabinets and doors, underlayment and industrial uses.

PLYRON • EXT • 0.328 IN. • APA • 000 • 11/32 CAT

PLYRON • EXP 1 • 0.234 IN. • APA • 000 • 1/4 CAT

Popping

See NAIL POPPING.

Prefabricated

In housing, all parts constructed or fabricated at the factory so that final construction only involves assembling and uniting standard parts at the job site. Commonly abbreviated as “prefab.” See PANELIZED CONSTRUCTION.

Prefinished

A ready-to-use panel with factory-applied finish – paint, overlays or coatings.

Preframed

Panelized building in which wall, floor or roof sections are framed and sheathed at the factory.

Preprimed

A panel with a factory-applied primer or undercoat needing only final finish after installation.

Preservatives

Products which prevent wood deterioration due to weather exposure, excessive moisture or insect attack. Treatments range from chemical pressure-impregnation, as for wood foundations, to application of paints or sealers.

Pressure-Preservative Treated

Wood treated with preservative by pressure-injecting treating solutions into wood cells. See WOOD FOUNDATION.

Primer

An undercoat applied to bare wood as a sealer and base for paint. See FINISHES.

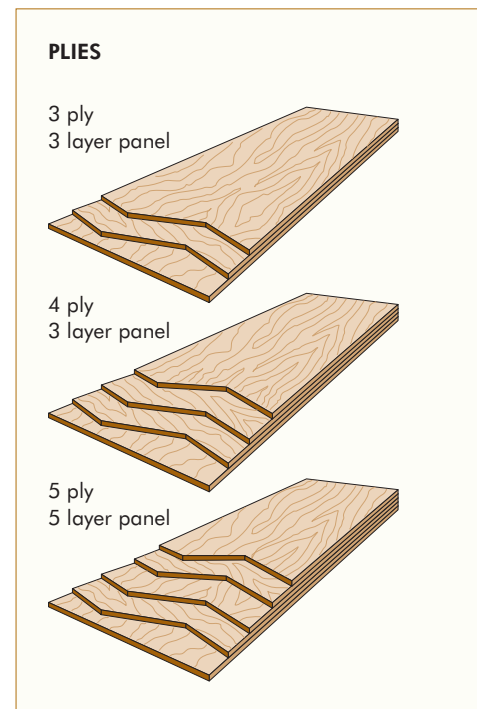

Product Standard

An industry product manufacturing or performance specification. APA trademarks carrying the PS 1 or PS 2 mark are identification by the manufacturer that the panel has been produced in conformance with U.S. Product Standard PS 1, Structural Plywood or Voluntary Product Standard PS 2, Performance Standard for Wood-Based Structural-Use Panels. PS 1 is a detailed manufacturing specification and alternate performance standard developed cooperatively by the softwood plywood industry and the U.S. Department of Commerce. PS 1 requirements and a supplementary set of APA specifications help ensure that plywood manufactured by APA member mills maintains its consistently high quality. PS 2 is a similar standard, without the detailed manufacturing specification, that relies on performance testing to assure that the structural panels meet realistic, rigorous standards. Other product standards developed by APA include, but are not limited to, APA PRI-400 Performance Standard for APA EWS I-Joists, APA PRR-401 Performance Standard for APA EWS Rim Boards, ANSI/APA PRR 410 Standard for Performance-Rated Engineered Wood Rim Boards, ANSI/APA PRP 210 Standard for Performance-Rated Engineered Wood Siding and ANSI/APA PRG 320 Performance Standard for Cross-Laminated Timber.

PRP®

See APA PERFORMANCE RATED PANELS.

Purlin

Subframing which supports roof decking where larger beams are main structural supports.

PWF

Abbreviation for Permanent Wood Foundation. See WOOD FOUNDATION.

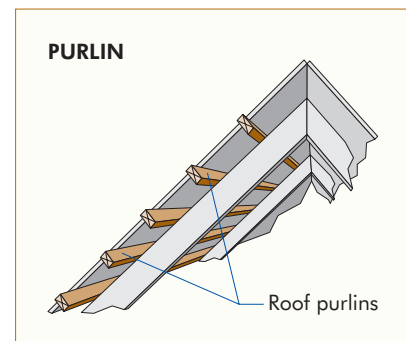

Q

Quality Inspection And Testing

Testing program administered by APA to ensure quality levels in member mills equal to or exceeding those prescribed by U.S. Product Standard PS 1, PS 2, or other national, international, or APA's own performance standards. The program is based on scientific random sampling. If quality levels are not maintained, APA trademark privileges may be withdrawn until compliance is restored.

R

R Value

A measurement of thermal resistance or ability to retard heat transmission. Used to compute insulating effectiveness.

Rabbet Joint

A joint formed by cutting a groove in the surface or along the edge of a board, plank or panel to receive another piece.

Racking Resistance

The ability of a panel to resist forces in the panel's plane tending to distort it from its rectangular shape.

Radiant Barrier Panels

Engineered wood panels with a thin layer of highly reflective aluminum facing that minimize heat gains in homes and buildings by reducing the impact of solar radiation. Radiant barriers can be incorporated into walls and floors, but the most common application is in attics.

Rafter

Sloping supporting member of a roof immediately beneath the sheathing.

Raised Grain

See GRAIN RAISE.

Rated Sheathing

See APA RATED SHEATHING.

Rated Siding

See APA RATED SIDING.

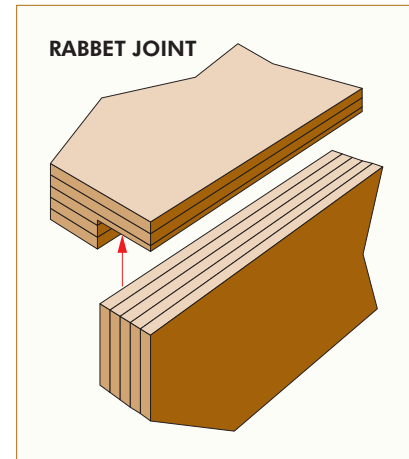

Repairs

Any patch, plug or shim in a veneer. A **patch** is a sound wood insert or synthetic material to replace a defect in veneer. “Boat” patches are oval shaped with sides tapering to points or small rounded ends. “Router” patches have parallel sides and rounded ends. “Sled” patches are rectangular with feathered ends.

A **plug** may be a circular or dogbone shaped wood patch or a synthetic filler of fiber and resin to fill openings and provide a smooth, level, durable surface. A **shim** is a long narrow wood or synthetic repair not more than 3/16 inch wide. Various other shapes of plugs or patches may be encountered. PS 1 specifies sizes, shapes and numbers of allowable patches in given veneer grades.

Resawn

See ROUGH SAWN.

Resilient Floor Covering

Any of the vinyl or asphalt-base floor coverings (tile or sheet) with enough “give” to resist deformation or denting from dropped objects. Resilient floor coverings installed over APA STURD-I-FLOOR or UNDERLAYMENT panels with “sanded face” provide smooth, stiff floors for comfortable walking.

Reverse Board And Batten

An APA 303 Siding surface treatment. Deep, wide grooves cut into textured siding surfaces during manufacture create striking, sharp shadow lines. See APA RATED SIDING.

Ridge Beam

The top horizontal member of a sloping roof, against which the ends of the rafters are fixed or supported.

Rigid Frame

Structural member functioning like an arch, comprised of studs and rafters fastened with plywood gussets or metal plates. Rigid frame construction eliminates the need for ceiling or tie members.

Rim Board®

The wood component that fills the space between the sill plate and bottom plate of a wall, or in second floor construction, between the top plate and bottom plate for two wall sections. The Rim Board is a continuously supported, full-depth structural element developed for use within a wood floor or roof assembly and performing a similar role as a starter or end joist when installed in a load bearing wall or non-load bearing wall perpendicular or parallel to the joist framing to transfer horizontal (shear) and vertical (compression) loads. It provides attachment for diaphragm sheathing, siding and/or exterior deck ledgers, and provides lateral support to floor or roof joists or rafters. APA Performance Rated Rim Boards® can be manufactured using plywood, oriented strand board (OSB), glued laminated timber (glulam) or structural composite lumber (SCL). Prefabricated wood I-joists may be used as a rim board. Rim Board is a registered trademark of APA.

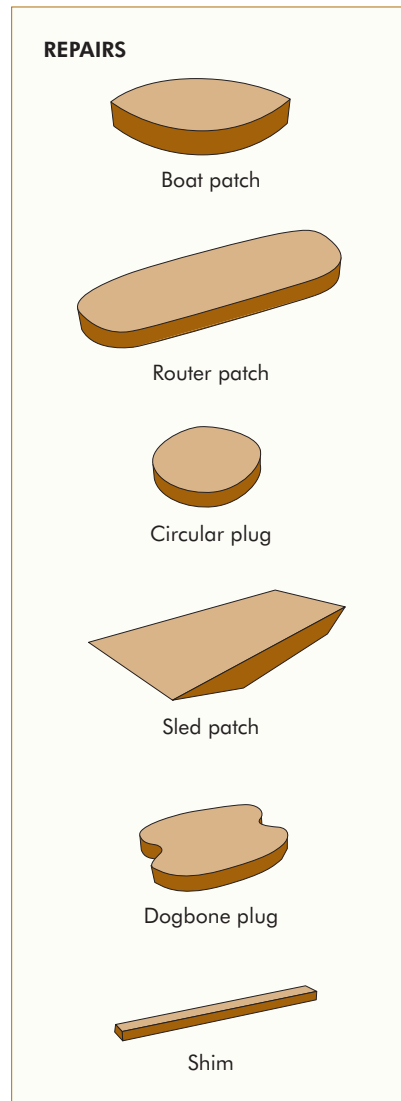

Ripping

Sawing wood in the direction of the grain. See CROSS CUTTING.

Rotary Peel

See PEELER LOG.

Rough Sawn

A decorative APA Siding treatment imparting a rough, rustic appearance by saw-scoring the surface of a panel during manufacture. Same as resawn. See APA RATED SIDING.

Router Patch

See REPAIRS.

S

Sanded Panels

Exposure 1 or Exterior plywood panels factory-sanded for applications where smoothness and appearance are important. These panels – with N, A or B-grade faces – are ideal for furniture, cabinets, doors, fences, signs, etc. Sanded panels save time because they may be finished with little or no preparation.

Sandwich Panel

See STRUCTURAL INSULATED PANEL.

Sapwood

Living wood of pale color near the outside of a log. Under most conditions, sapwood is more susceptible to decay than heartwood.

Scarf Joint

An angled or beveled joint in plywood splicing pieces together. The length of the scarf is 5 to 12 times the thickness.

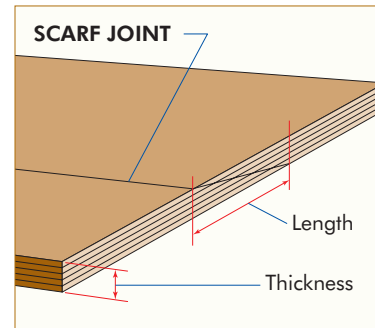

SCL

See STRUCTURAL COMPOSITE LUMBER.

Screws

Use wood screws for attaching wood structural panels where nails will not provide sufficient holding power. Sizes shown below are minimum; use longer screws where work permits. Lubricate screws with soap if they are hard to drive. If used for sheathing, use same spacing as recommended for nails.

SCREW SIZES

Wood Structural Panel Thickness (in.)	Application	Screw Length (in.)	Screw Size	Drill Size for Shank (in.)	Drill Size for Root of Thread (in.)
3/8 – 1/2	Subfloor, Wall	1-3/4	8	11/64	7/64
3/8 – 1/2	Roof	1-7/8	10	13/64	1/8
19/32 – 1	Subfloor, Wall or Roof	2-1/2	10	13/64	1/8
1-1/8 – 1-1/4	Subfloor, Wall or Roof	2-3/4	10	13/64	1/8

SCREWS

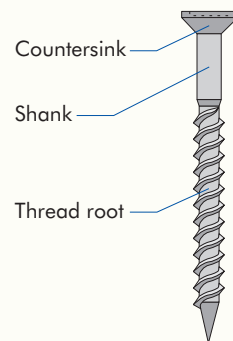

Seasoning

Removal of moisture from wood to improve its serviceability, sometimes by air drying – drying by air exposure without artificial heat – or kiln drying – drying in a heated chamber with artificial heat. Plywood veneers and OSB furnish are seasoned before lay-up and gluing into panels. See FURNISH.

Shear Wall

See DIAPHRAGM.

Sheathing

The structural covering, usually of wood panels or boards, on the outside surfaces of framing. It provides support for construction, resists snow and wind loads and forms backing for attaching exterior facing materials such as wall siding, roof shingles or underlayment in double-layer floors. APA RATED SHEATHING is recommended for conventional applications. See APA RATED SHEATHING.

Shim

See REPAIRS.

Shiplap

Jointing in which ends or edges are notch-milled to overlap and form a rabbet joint.

Shop Cutting Panel

Panel rejected as not conforming to grade requirements defined in the Product Standard. Panel identification, a separate mark that does not mention the Standard, reads: “Shop Cutting Panel – All Other Marks Void.” Normally a “shop” panel’s defect may be eliminated by cutting the panel into smaller pieces for applications not governed by building codes.

Siding

See APA RATED SIDING.

Sill Plate

The lowest framing member of a structure, resting on the foundation and supporting the floor system and the uprights of the frame.

Single Floor

A single-layer wood structural panel flooring system combining subflooring and underlayment. See APA RATED STURD-I-FLOOR.

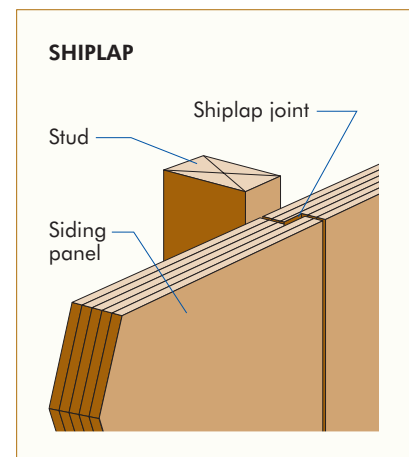

Single Wall

See APA STURD-I-WALL.

Sized For Spacing

A notation in APA RATED SHEATHING and RATED STURD-I-FLOOR trademarks indicating panels may be trimmed during manufacture to length and width tolerances of +0, -1/8 inch. This trimming is designed to encourage proper panel spacing. See PANEL SPACING.

Sled Patch

See REPAIRS.

Soffit

The underside of the roof overhang. Wood structural panels are often used as finishing materials for soffits.

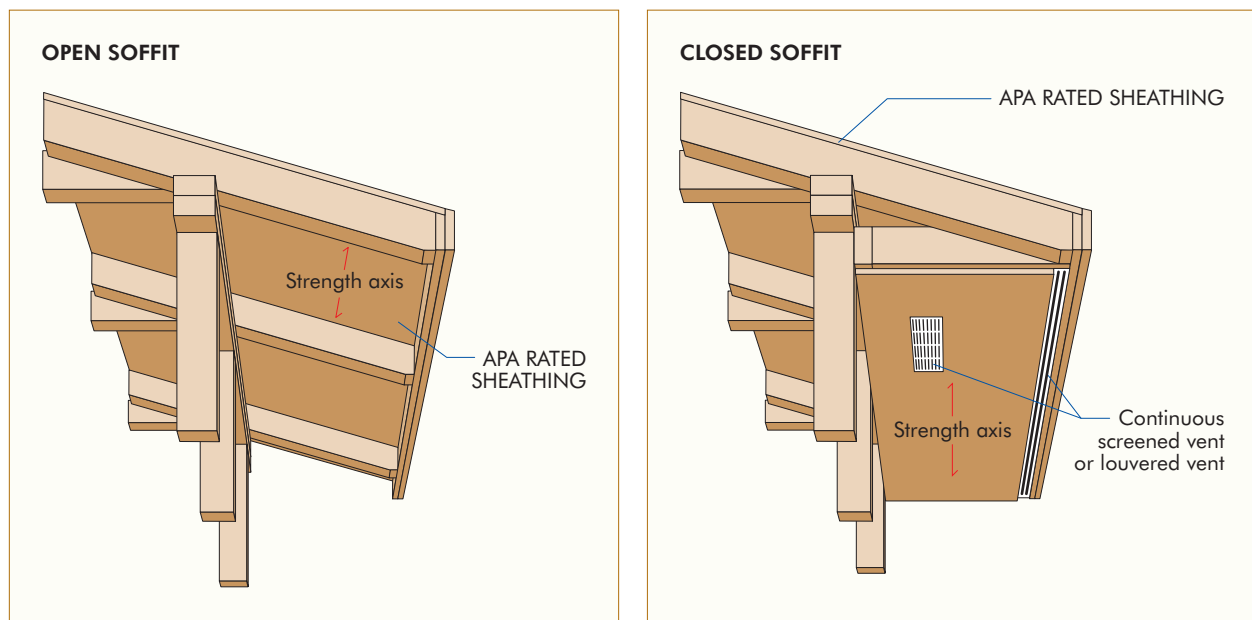

Softwood

Wood of the coniferous or needleleaved trees – pine, fir, spruce, hemlock – as distinct from the hardwood of the deciduous or broadleaved trees – oak, ash, maple, walnut. The term has only a general reference to actual wood hardness. Construction and industrial plywood and other panel products may use either variety, but are more commonly manufactured of softwoods. See HARDWOOD.

Solid Core

See PLUGGED CORE.

Sound Transmission Class

See STC.

Spacing

See PANEL SPACING.

Span Rating

APA RATED SHEATHING, APA RATED STURD-I-FLOOR and APA RATED SIDING carry numbers on their trademarks called Span Ratings. These denote the maximum recommended center-to-center spacing in inches of supports over which the panels should be placed in normal code-conforming construction. Except for APA RATED SIDING panels, the Span Rating applies when the long panel dimension or strength axis is across supports, unless the strength axis is otherwise identified on the panel. The Span Rating of APA RATED SIDING panels applies when panels are installed vertically (parallel to studs).

The Span Rating on APA RATED SHEATHING panels appears as two numbers separated by a slash, such as 32/16, 48/24, etc. The left-hand number denotes the maximum recommended spacing of supports when the panel is used for roof sheathing with the **strength axis of the panel across three or more supports (two or more spans)**. The right-hand number denotes the maximum recommended spacing of supports when the panel is used for subflooring with the **strength axis of the panel across three or more supports (two or more spans)**. A panel marked 32/16, for example, may be used for roof decking over supports up to 32 inches on center or for subflooring over supports up to 16 inches on center.

The Span Rating on APA RATED STURD-I-FLOOR and APA RATED SIDING panels appears as a single number. APA RATED STURD-I-FLOOR panels are designed specifically for single-floor (combined subfloor-underlayment) applications under carpet and pad and are manufactured with Span Ratings of 16, 20, 24, 32 and 48. The Span Ratings for APA RATED STURD-I-FLOOR panels, like those for APA RATED SHEATHING, are based on application of the panel with the **strength axis of the panel across three or more supports (two or more spans)**. APA RATED STURD-I-FLOOR may be also used in roof decking applications.

Similarly, the single-number Span Ratings on APA RATED SIDING panels are the maximum recommended center-to-center spacings of studs (16 or 24 o.c.) when the panel is applied vertically direct to studs (or over nonstructural wall sheathing such as fiberboard, gypsum or rigid foam insulation sheathing). All RATED SIDING panels may be applied horizontally direct to studs spaced 16 or 24 inches on center, provided horizontal joints are blocked. When RATED SIDING is used over APA RATED SHEATHING or lumber, the Span Rating refers to the maximum recommended spacing of vertical rows of nails rather than studs.

Panels with a given Span Rating may be manufactured in more than one thickness and vice versa, because of varying panel compositions and configurations.

Species Group

See GROUP NUMBER.

Stains

See FINISHES.

STC

Sound Transmission Class. A measure of the ability of a wall or floor assembly to reduce noise transmission.

Stressed-Skin Panel

An engineered structural panel assembly for roof deck or floor applications built of plywood sheets glued to framing members. The quick-covering assembly has greater load carrying capacity than would its individual members if installed separately.

Stringer

A lumber member supporting a series of cross members. Frequently applied to stair supports.

Structural Composite Lumber (SCL)

Includes laminated veneer lumber (LVL), laminated strand lumber (LSL), oriented strand lumber (OSL) and parallel strand lumber (PSL). It is a family of engineered wood products created by layering dried and graded wood veneers, flakes or strands bonded with an exterior adhesive into blocks of material known as billets. The wood fibers are primarily oriented along the length of the wood composite. Cured in a controlled process, SCL is typically available in various thicknesses and widths and is easily worked in the field using conventional construction tools.

Structural I

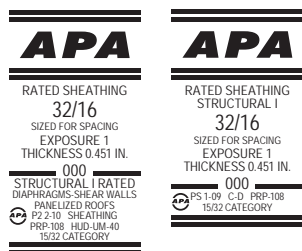

Unsanded grade for use where shear and cross-panel strength properties are of maximum importance, such as panelized roofs and diaphragms. All plies in Structural I plywood panels are special improved grades and panels marked PS 1 are limited to Group 1 species. Other panels marked Structural I Rated qualify through special performance testing. Manufactured with Exterior or Exposure 1 bond classification. See APA RATED SHEATHING.

Structural Insulated Panel (SIP)

A section of layered construction made up of high-strength structural wood panel faces or “skins,” attached to both sides of low-density core materials such as plastic foam or honeycomb paper fillers. Sometimes referred to as sandwich panel or stress-skin panel.

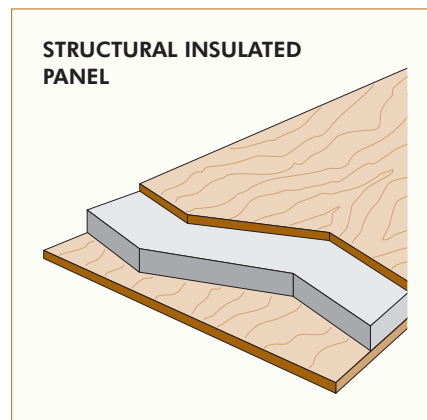

Stud

The basic vertical framing members of walls, usually 2x4 or 2x6. Studs are traditionally spaced 16 inches on center, sometimes 24 inches as in the Engineered 24" Framing System. See SPAN RATING.

Sturd-I-Floor

See APA RATED STURD-I-FLOOR.

Sturd-I-Wall

See APA STURD-I-WALL.

Subflooring

APA RATED SHEATHING panels applied directly over floor joists which will receive an additional underlayment layer. Wood structural panels provide strength and stiffness. They also reduce the number of floor joints as compared with board sheathing. See UNDERLAYMENT.

Swelling

See EXPANSION and PANEL SPACING.

Synthetic Repairs

See REPAIRS.

T

T-Beam

Beam resembling a “T” in cross section. Several side-by-side T-beams acting as a unit may form a floor. This principle accounts for the increased stiffness of glued floors.

Telegraphing

Show-through on a smooth overlaid wood structural panel surface of underlying grain or defects.

Testing Agency

See APA – *The Engineered Wood Association* and QUALITY INSPECTION AND TESTING.

Texture 1-11®

APA trade name for a special plywood RATED SIDING panel 19/32 inch or thicker with 3/8-inch-wide vertical grooves typically spaced 4 or 8 inches on center. Shiplapped edges maintain pattern continuity when installed. See APA RATED SIDING.

Textured Plywood

Panels with a variety of machined surface textures. Available as Exterior bond for siding and other outdoor uses and for interior wall paneling. See APA RATED SIDING.

303® Specialty Siding

See APA RATED SIDING.

Tongue-And-Groove Joint

A system of jointing in which the rib or tongue of one member fits exactly into the groove of another. A specially designed APA tongue-and-groove panel edge joint is particularly efficient in transferring the load across the joint. Some APA RATED STURD-I-FLOOR T&G panels measure 47-1/2 inches across the face.

Touch-Sanded Panels

Wood structural panels “sized” to uniform thickness by light surface sanding during manufacture. Sander skips are admissible. Normally applied to C-Plugged faces.

Trademark

See APA TRADEMARK.

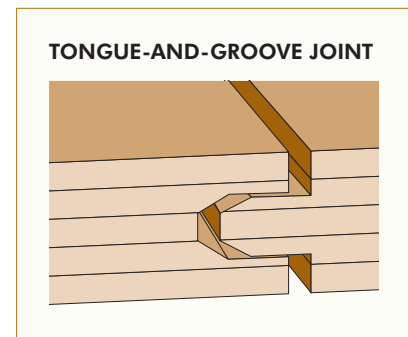

Truss

A combination of members usually arranged in triangular units to form a rigid framework for supporting loads over a span. Parallel chord trusses are also used for floor and roof supports.

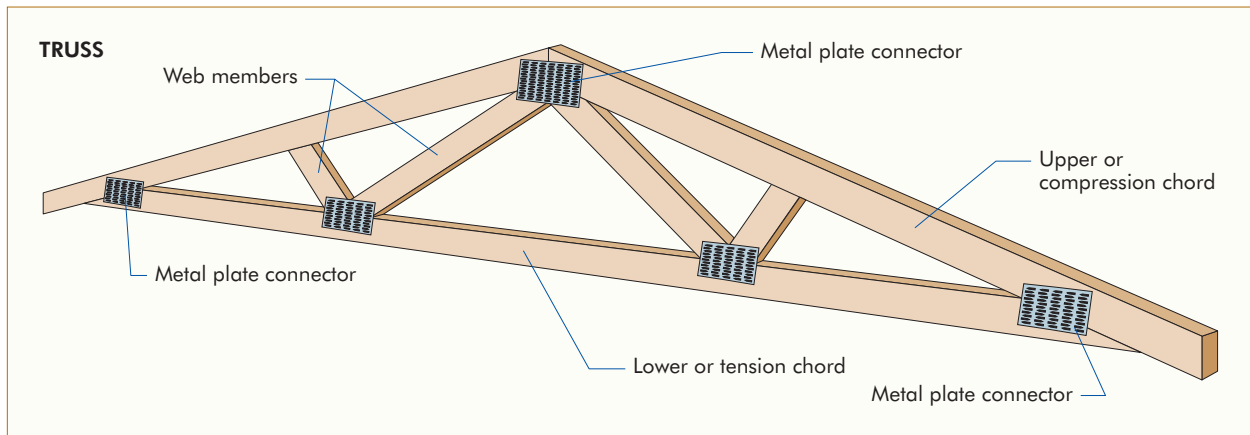

U

Underlayment

A material applied over subflooring and directly beneath nonstructural finish flooring, such as tile or carpeting. Wood panel underlayment provides a smooth surface for finish flooring and excellent puncture and indentation resistance. See SUBFLOORING, PLUGGED CROSSBAND UNDER FACE and UNDERLAYMENT GRADE.

Underlayment C-C Plugged Exterior

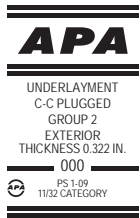

An Exterior underlayment panel with a touch-sanded C-Plugged face ply. Common uses include underlayment in conditions of severe moisture or humidity (bathrooms, kitchens), refrigerator or controlled atmosphere storage rooms, exterior balconies and decks, pallet bins, tanks, boxcar and truck floors and linings, and open soffits.

Underlayment Grade

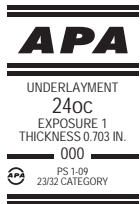

PS 1-designated, touch-sanded panels designed as a base for finish flooring such as carpeting (and tile or linoleum when specified with a sanded face) and installed over structural subflooring such as APA RATED SHEATHING. These panels are manufactured with exterior glue designed for applications subject to long construction delays or similar moisture exposure.

Unsanded Panels

Exposure 1 or Exterior sheathing grade panels designed for utility applications and left unsanded for greater stiffness, strength and economy.

V

Vapor Retarder

A material (such as plastic film) which controls moisture transmission through walls and other building elements. Often combined with insulation to control condensation. A vapor retarder should be installed on the warm side of walls.

Veneer

A thin sheet of wood laminated with others under heat and pressure to form plywood, or used for faces of composite panels. Also called ply.

Veneer Grade

The standard grade designations of softwood veneer used in panel manufacture. The six grades are:

- N** Special order “natural finish” veneer. Select all heartwood or all sapwood. Free of open defects. Allows some repairs.
- A** Smooth and paintable. Neatly made repairs permissible. Also used for natural finish in less demanding applications.
- B** Solid surface veneer. Router or sled repairs and tight knots permitted.
- C** Improved C veneer with splits limited to 1/8 inch in width and knot-holes and borer holes limited to 1/4 inch by 1/2 inch.
- C** Plugged Knotholes to 1 inch. Occasional knotholes 1/2 inch larger permitted providing total width of all knots and knotholes within a specified section does not exceed certain limits. Limited splits permitted. Minimum veneer grade permitted in Exterior plywood.
- D** Permits knots and knotholes to 3 inches in width and 1/2 inch larger under certain specified limits. Limited splits permitted.

Void

See CORE GAP.

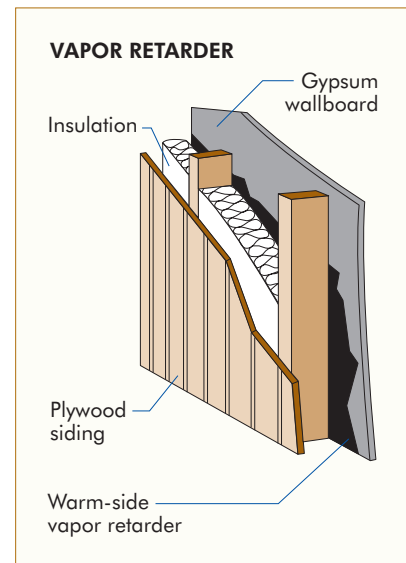

W

Waferboard

Panels manufactured from reconstituted wood wafers randomly aligned, as opposed to oriented strands, bonded with adhesive under heat and pressure. See ORIENTED STRAND BOARD.

Wainscot

The wooden lining of the lower part of an interior wall.

Waler

Horizontal timbers used to brace concrete form sections.

Warping

Bending or twisting from a straight line. An improperly seasoned piece of lumber may warp when exposed to heat or moisture. To reduce the possibility of warping, protect wood panels from dampness or moisture and follow APA spacing recommendations. Painting and water-repellent dips will minimize moisture absorption. Sealing all edges and back-priming also reduces the chances of warping in cabinet doors. See PANEL SPACING.

Water Repellents

Wood preservatives with water-resistant properties.

Web

See BOX BEAM and TRUSS.

Wicking

The tendency of wood to draw moisture up through its cells by capillary action in the direction of the grain.

Wood Foundation

A residential and light frame foundation system utilizing pressure-preservative-treated plywood panels and wood framing in place of poured concrete footings and masonry or poured concrete walls. The system is commonly known as the Permanent Wood Foundation (PWF). The system can often be installed on a prepared site in less than half a day in nearly any weather, speeding construction and reducing costs. The PWF is also applicable to crawl-space foundation construction.

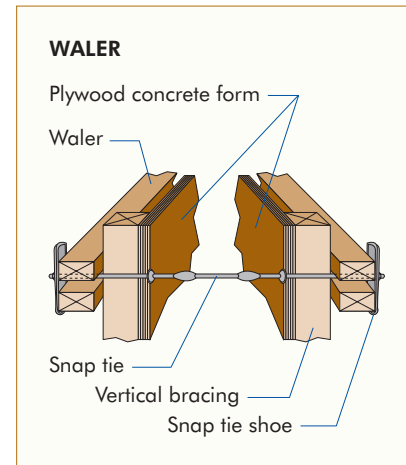

Z

Z Flashing

A Z-shaped piece of galvanized steel, aluminum or plastic installed at horizontal joints of panel siding to prevent water from entering wall cavity.

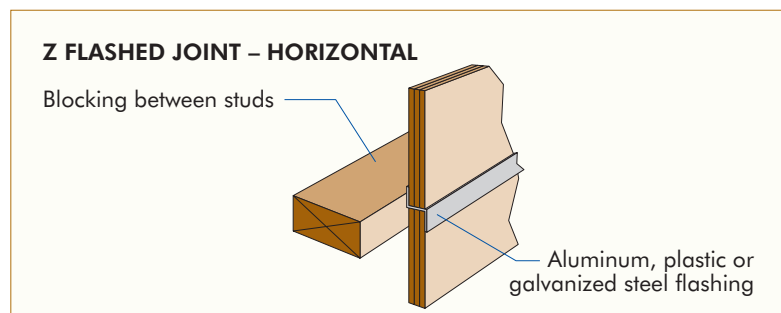

Engineered Wood Handbook and Grade Glossary

We have field representatives in many major U.S. cities and in Canada who can help answer questions involving APA trademarked products. For additional assistance in specifying engineered wood products, contact us:

APA HEADQUARTERS

7011 So. 19th St. ■ Tacoma, Washington 98466
(253) 565-6600 ■ Fax: (253) 565-7265

PRODUCT SUPPORT HELP DESK

(253) 620-7400
E-mail Address: help@apawood.org

DISCLAIMER

The information contained herein is based on APA – The Engineered Wood Association’s continuing programs of laboratory testing, product research, and comprehensive field experience. Neither APA, nor its members make any warranty, expressed or implied, or assume any legal liability or responsibility for the use, application of, and/or reference to opinions, findings, conclusions, or recommendations included in this publication. Consult your local jurisdiction or design professional to assure compliance with code, construction, and performance requirements. Because APA has no control over quality of workmanship or the conditions under which engineered wood products are used, it cannot accept responsibility of product performance or designs as actually constructed.

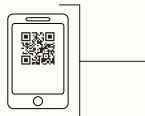

www.apawood.org



Form No. X505S/Revised June 2012

