

TYPICAL REPAIR METHOD FOR A CUT 2x3 OR 2x4 TOP CHORD

SITUATION BEFORE REPAIR

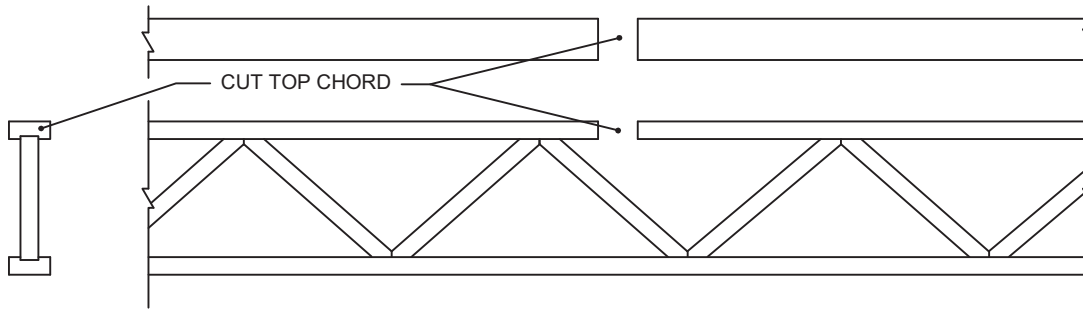

SITUATION AFTER REPAIR

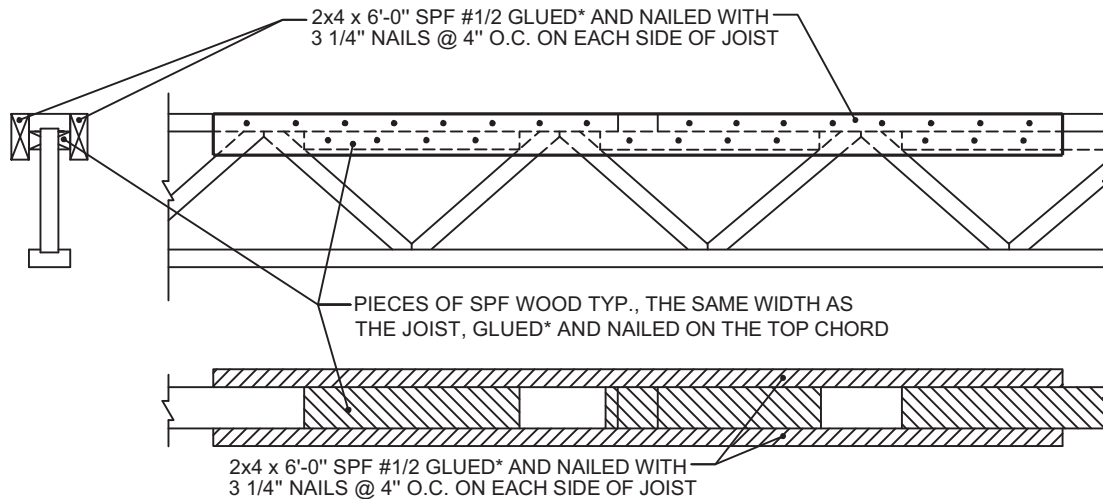

*PL PREMIUM GLUE

RTF-005-18

IMPORTANT NOTICES

This detail drawing is valid for uniform residential loads.
For other types of loads, contact the manufacturer.
Check out the www.openjoisttriforce.com website for the latest updates.

